

## Dual Unilight

### The better, brighter mini floodlight

#### FEATURES

- Luminaire is designed for outdoor lighting applications where a directed light source is required.
- Powered by a separate solar array, ideal for sign lighting, monuments, up lighting for landscaping, building security, perimeter fence, security lighting, remote buildings, and other floodlight applications.
- Maintenance free, vandal-resistant construction.
- Installs quickly and easily.
- Super efficient, bright, white light 5,100 K, state-of-the-art LED light source - the most efficient and aesthetically pleasing white light source in this wattage range
- Excellent color rendering optimizes human visual acuity and contrast, offering best in class night-time vision.
- “Instant-on” – no warm up or cold start issues.
- Unlike conventional lights, no risk of hazardous disposal - CF, CCFL, LPS and HPS contain mercury.
- LEDs rated at 70,000 hours (L-70) for 15+ years of brilliant illumination.
- FivePlus™ Warranty includes 10 years on electronics, wiring, fixtures and 20 years on mounting hardware and solar panels.

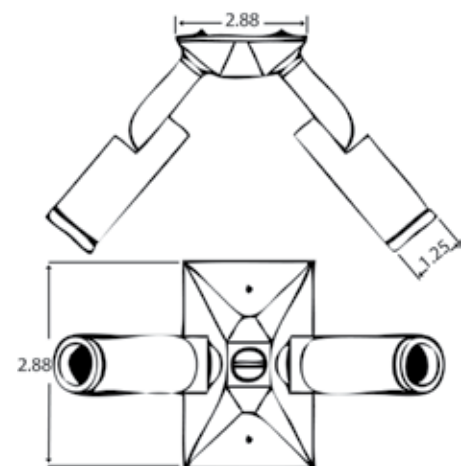

#### SPECIFICATIONS

- Black powder-coat finish.
- Aluminum construction.
- Mounts on any metal post - single j-box.
- 12 volt.
- 6 watts (3 watts per Unilight).
- Weight: 12 pounds



rev. 0510 MRKT-DUALUNI-001