

Transit Shelter Security Lighting Solar LED Lighting for Tolar Shelters



Installation and
Owner's Manual

Sol[®] 
Reliable. Renewable. Remarkable.

Introduction

IMPORTANT SAFETY INSTRUCTIONS - SAVE THESE INSTRUCTIONS



This manual contains important instructions for the Transit Shelter Solar Lighting systems that shall be followed during installation and maintenance of the charge controller.

The SOL Transit Shelter Solar Lighting system is a patented, off-grid, standalone, solar-powered lighting system. Years of engineering, development, and testing ensure that this system meets or exceeds all performance and reliability specifications. Every system that leaves our factory has been quality control tested and inspected to assure you of an easy installation and highly dependable performance. All mechanical fittings and electrical connections are designed for simple and reliable installation. The system is ready for use immediately after the components are mounted and the plug and play connectors are joined.

IMPORTANT NOTES AND WARNINGS

This installation and instruction manual provides installation, operation, and maintenance instructions for the SOL Transit Shelter Solar Lighting system. The entire contents of this manual should be thoroughly reviewed and understood prior to installing this equipment. Do not discard this manual. It contains complete maintenance instructions, a troubleshooting chart, and a spare parts list. To insure proper operation of this equipment, it is important that the equipment be utilized for its intended use. Any use of this equipment for purposes other than those intended will void all warranties.



Installation and/or troubleshooting should be performed only by qualified personnel. Follow local codes at all times during installation of the SOL Transit Shelter Solar Lighting system.



Be very careful when working with batteries.



Do not allow bare ends of the wires to touch each other or grounded metal parts while connected to the controller(s). This will damage the controller(s).

Operational Principles

The SOL Transit Shelter Solar Lighting system is designed to provide reliable operation and illumination all year. The solar array (the photovoltaic panel, or PV panel) re-charges the battery (or batteries) each day, replacing energy that was used during the previous evening so that illumination can again be provided during the following evening. The system is designed with a reserve, so that regular illumination will continue to be provided during periods of rainy or cloudy weather. The controller monitors battery condition and will shut off illumination if the battery charge drops below a specified level. This may occur if there is a prolonged rainy or cloudy weather or if the solar array is shaded during part of the day. The controller automatically restarts the system when the condition is corrected and the battery charge returns to the specified level, protecting the batteries.

General Information

Site Selection and Preparation

Locate and install the PV panels in an area where the PV panels can face the equator (due south in the Northern hemisphere) and not shaded by trees, poles, buildings, or other objects during the day (Figure 1).

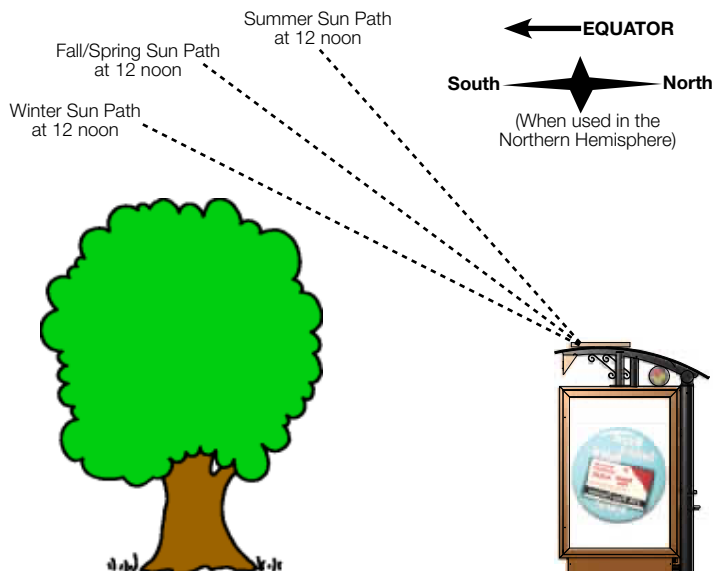

Do not locate in an area where there is excessive ambient or reflected light at night which may simulate daylight and cause the system controller to turn off the system. Installing in a location where the solar panels are shaded during part of the day will prevent the solar panel from fully charging the battery, reducing the hours of nighttime illumination and possibly damaging the battery.

IMPORTANT: If installed near a tree, check the tree branches every three months and trim when needed.

Installation of the solar light system must comply structural engineering requirements for local and national codes. Though designed for ease the TSSL should be installed by a qualified personnel.

System Specifications

ITEM	DESCRIPTION
Solar Panel	Poly-crystalline, Framed, with high-transmission 3mm tempered glass cover or Flexible, Amorphous silicon ThinFilm with butyl adhesive coating
Solar Panel Mounting Assembly	Architectural Angle Aluminum Mounting Legs (for panel option)
Battery	NRGLife™ - Sealed, No-maintenance, Gel Cell Lead Acid
Battery Charge Indicator	Single green LED indicates charging. Single red LED indicates load present/low voltage disconnect.
Power Management	Solid-state charge controller with low voltage disconnect (LVD)
Hardware	Stainless steel, tamper resistant
Illumination Technology	SOL UniLights
Illumination "On" Time	System Dependent
Minimum Autonomy	5 days
Operating Temperature	-30°C to + 80°C (-22°F to + 176°F)
Weight	Varies With Unit Size

Tools required

The following tools are recommended to install the Transit Shelter Solar Light System.

- Phillips screwdriver
- Flathead screwdriver
- Adjustable wrench
- Basic socket set
- 5/16" hex head driver
- Digital volt meter (optional)

Fastener List - Refer to Packing list for complete parts list

* Recommended Torque

Fastener	Qty.	Torque*		Qty.	Torque*
1/4-20 jack nut	4		#14 x 1.5" Tek screws	8	20 in lbs
#14 x 1" Tek screws	16	20 in lbs	1/4-20 x1" jack screw bolts	4	20 in lbs

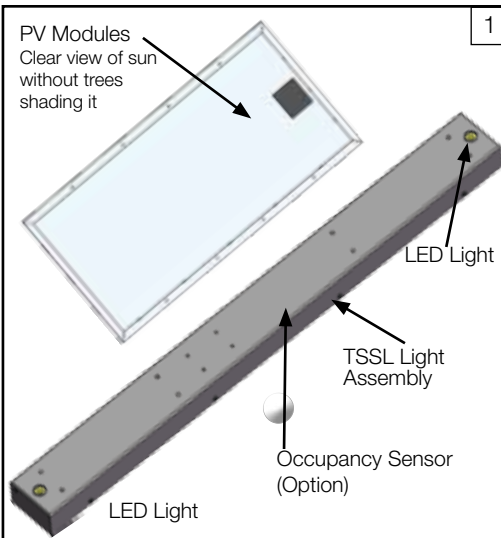

TSSL system is packed in two cartons. One contains the solar module, and the other contains the light bar assembly, solar panel mounting angles, mounting brackets, and hardware. Everything comes fully wired and the control system is factory set for dusk to dawn operation.

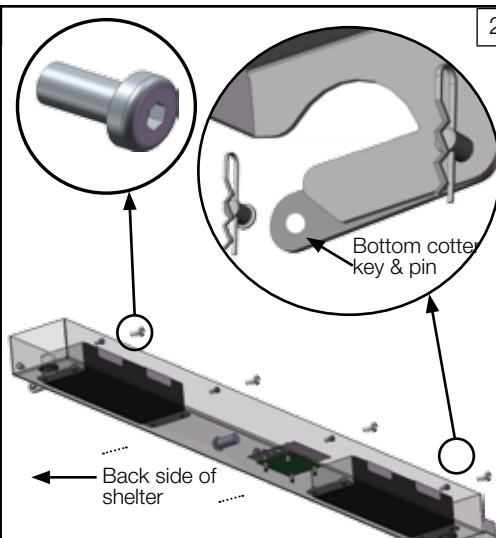

Open the cartons and place components on the cardboard packaging to protect the powder coated surfaces and surface of PV module(s). Open the light assembly by removing the tamper proof security screws and remove the bottom cotter key and pin from upper housing.

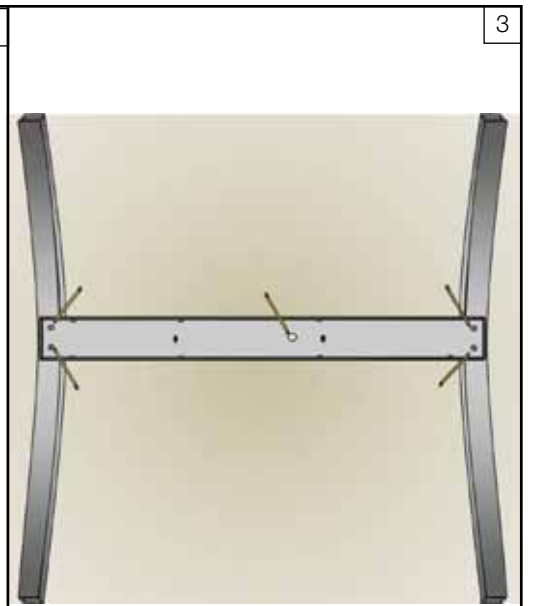

Using the upper housing as a template, mark the five holes to be drilled in the shelter. Drill 3/8" through shelter mounting channels and drill 7/8" hole in shelter roof.

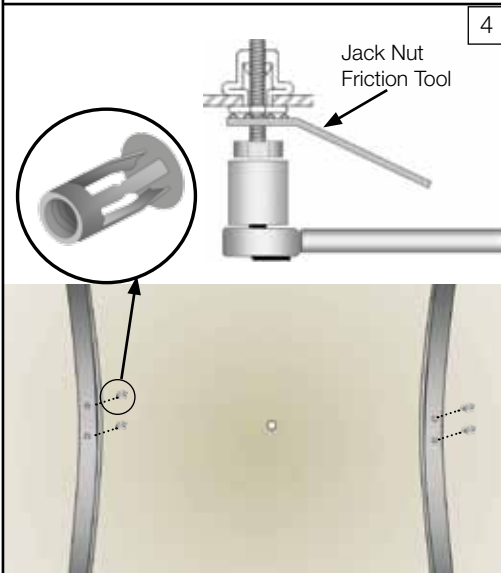

Insert and fasten 4x 1/4-20 jack nut in the four mounting holes. Hold the friction tool stationary and collapse the jack nut. Use constant pressure against the friction tool with a ratchet. **Do not use a power drill to install the jack nuts.**

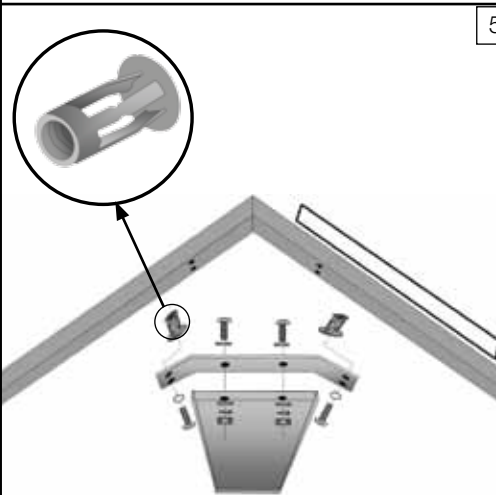

For high peak roof shelter types, use the supplied adapter plate as a template for the jack nut mounting holes (4 per plate). The main housing is attached to the adapter plate using through bolts.

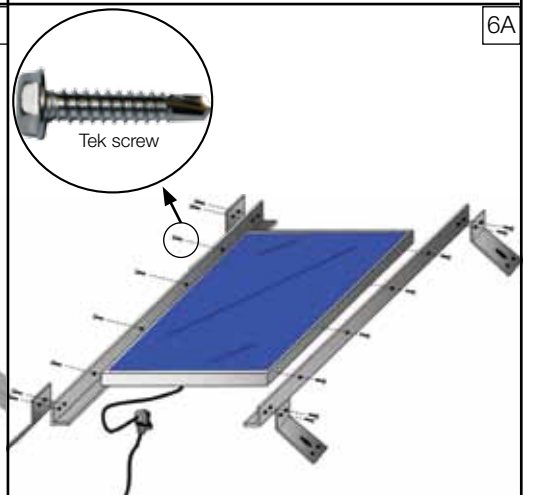

Barrel Roof Mounting: Fasten the mounting angles to the PV panel frame using 16 x #14 x 1" Tek screws provided. The PV panel(s) should be centered on the aluminum angles. Insert PV harness cord into hole of shelter roof. Let 15" of cord hang inside the shelter.

6B

Barrel Roof Mounting: Mount PV module using 8 x #14 x 1.5" Tek screws provided.

6C

Peak/Flat Roof Mounting: Fasten the mounting angles to the PV panel frame using 16 x #14 x 1" Tek screws provided. The PV panel(s) should be centered on the aluminum angles. Insert PV harness cord into hole of shelter roof. Position panel to cover the fitting when mounted. Let 15" of cord hang inside the shelter.

6D

Peak/Flat Roof Mounting: Mount PV module using 8 x #14 x 1.5" Tek screws provided. Ensure that the panel is mounted on the surface most facing towards the equator or due South in the Northern hemisphere.

7

Feed the hanging PV harness cord through the upper section of the light assembly, secure cord grip, and mount it to roof bows with 4x 1/4-20 x 1" jack screw bolts.

8

IMPORTANT!
Hang the lower part of light assembly as shown and reinstall the cotter pins and keys before proceeding further. Connect battery plug first followed by PV connector. LED's will flash briefly to indicate correct connection. See wiring diagram for details.
Note: Optional Occupancy sensor comes pre wired to the TSSL.

9

Close unit and ensure all wires are tucked into unit. Secure with 3-4 tamper resistant screws. Insert TEST key and turn to TEST position. Wait 3-4 minutes for light to come on. Turn back to ON position, remove key and add remaining security screws.

Sol, Inc.
Reliable. Renewable. Remarkable.
Sol, Inc.
Palm City, FL
Tel: (772) 286-5461
service@solarlighting.com
www.solarlighting.com
Manufactured in the USA
01000-11 Rev. 4

Optional ThinFilm Installation

Install the ThinFilm flexible solar array in accordance with all applicable codes.



Remove ThinFilm flexible solar array from packaging and place in desired horizontal surface of roof shelter to determine correct positioning. Panel should be facing Equator (south in Northern Hemisphere). Determine best route for PV harness route to the upper section of the light assembly.



Connect flexible solar array MC type IV connectors to PV harness. Route PV Harness from shelter to upper section of light assembly.

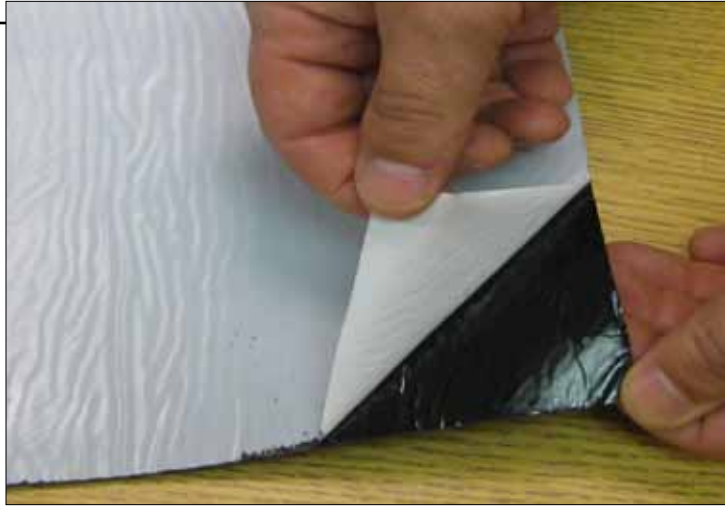

Carefully remove the protective film on the back of the flexible solar array and secure on roof shelter by gently pressing to adhere. Follow remaining steps in TSSL Quick Install Guide.
WARNING: Butyl adhesive coating is designed for first time adhesion and should not be repositioned after adhering.



Elbow seal tight



It is recommended that the PV harness be routed around shelter roof to upper light assembly and discretely secured by clips or other method to ensure a neat installation of the ThinFilm panels(s). Alternately, a 7/8" hole can be drilled in shelter roof above upper light assembly to route harness directly and secure opening with elbow seal tight. Routing around shelter and securing the excess PV harness is the preferred method.

TSSL Parts List

REVISION HISTORY

REV.	DESCRIPTION	DATE	APPROVED
A	RELEASE PER ECN09-049	10/27/2009	

NOTES:

1. ASSEMBLE AS SHOWN.
2. TIGHTEN ALL FASTENERS SECURELY.
3. WIRING AND ROUTING: SEE DWG. 89-5002-200.
4. BATTERY INSTALLED TERMINALS OUT FOR TESTING.

ITEM	QTY	PART NUMBER	DESCRIPTION
20	2	951000-004	CLEVIS PIN, 5"
19	1	89-5002-100	ASSY. HARNESS, KEY SWITCH, TSSL
18	2	951000-007	ARMATURE HINGE, TSSL
17	2	17015-015	RING, RETAINING, 1.0" DIA SHAFT
16	2	WEXTLW #8-32	#8-32 EXT L/W 410 SS
15	4	17008-001	NUT, HEX #8-32
14	2	13000-004	CLAMP, CABLE, 7/16"
13	1	691011-001	SHIELD, CONTROLLER, TSSL-CP
12	8	WEXTLW1/4	WASHER, 1/4" EXTERN. TOOTH LOCK
11	8	WFS1/4	WASHER, 1/4" SS FLAT
10	8	NHS1/4-20	NUT, 1/4"-20 SS HEX
9	2	700100-100	UNILIGHT, SIGNAL
8	8	12000-013	STANDOFF, M/F 8-32 X 1/2"
7	1	80018-003	CONTROLLER, TSSL, 2A
6	4	86002-005	BATTERY, 6V 12AH
5	8	1PB8HCS8-32X.50	SEC. SCREW #8-32X1/2" SS W/PIN IN
4	2	17002-011	O-RING (943 ID X 1.45 OD)
3	2	951000-003	RETAINER, BATTERY
2	1	951000-002	COVER, LIGHT BAR, TSSL, LED
1	1	951000-001	HSG, LIGHT BAR, TSSL, LED

CONTROLLED COPY
 PROPRIETARY AND CONFIDENTIAL
 INFORMATION. THE INFORMATION CONTAINED
 HEREIN IS THE PROPERTY OF SOL INC. AND IS
 TO BE USED ONLY FOR THE INTENDED
 PURPOSES OF SOL INC. (UNLESS OTHERWISE
 SPECIFIED).

SOLE INC.
 3210 SW 42ND AVENUE
 PALM CITY, FLORIDA 34990
 PH: 772-286-9461 FAX: 772-286-9616

TITLE: ASSY, LIGHT BAR, TSSL, LED
 SIZE: DWG. NO. C 951000-100
 REV. A
 SCALE: 1:15 WEIGHT: SHEET 1 OF 1

TSSL Wiring Diagram

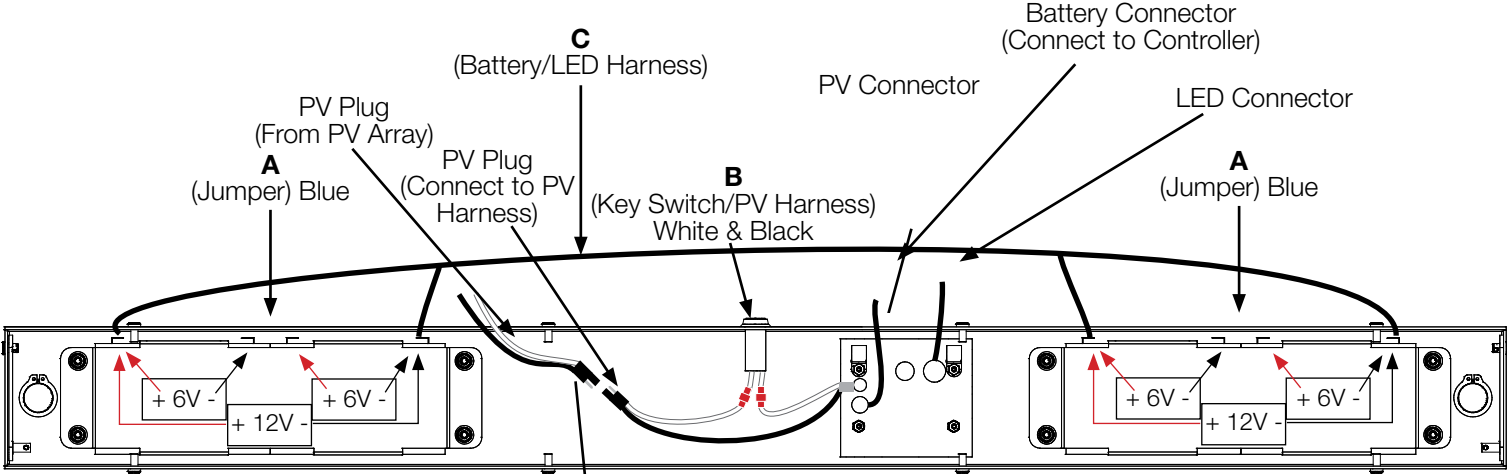

Battery voltage (for the pair) can vary from 11.0V to 14.0V depending on charging status and state of charge.

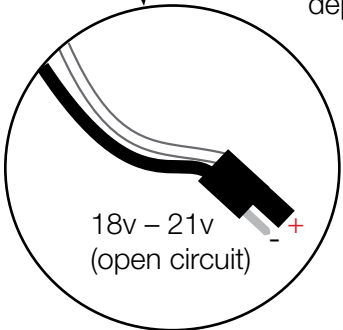

When the controller begins to charge the battery, the PV voltage will measure close to battery voltage.

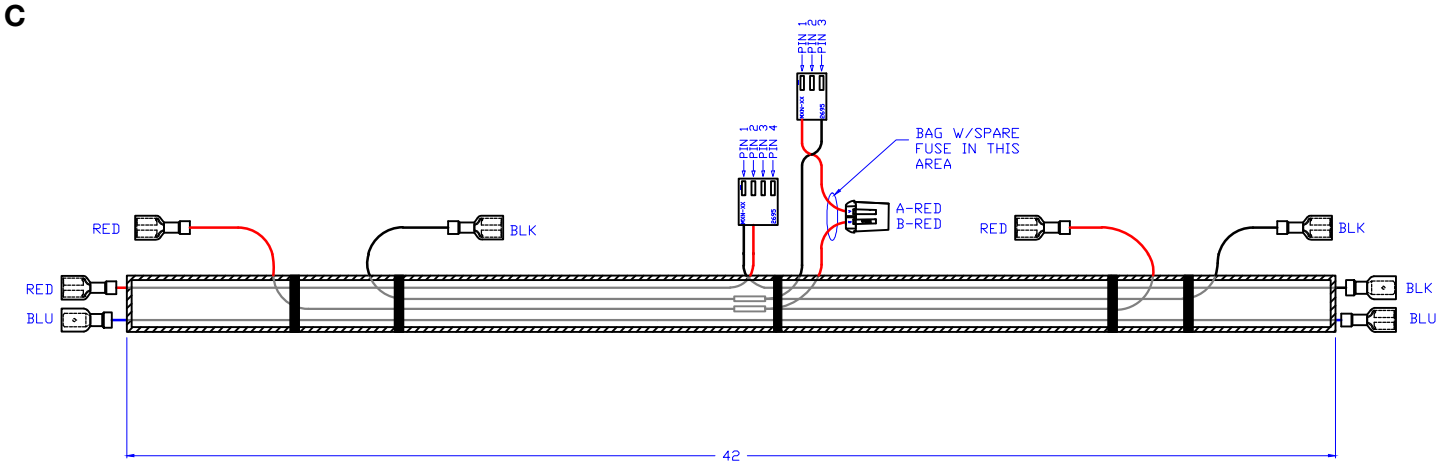
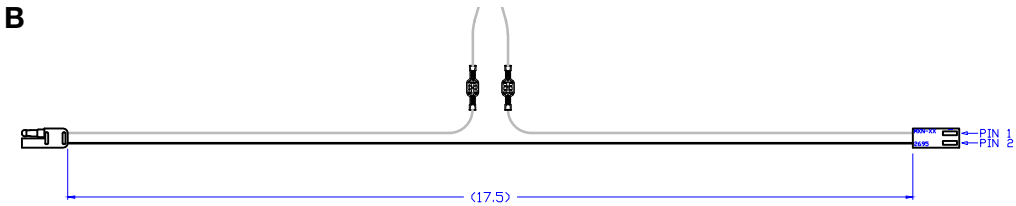
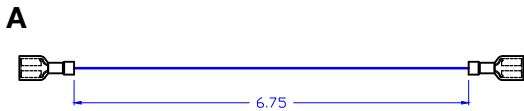

TESTING PROCEDURE

How to Test your Transit Shelter Security Light System

Check all harnesses to ensure adequate connections, and check in-line fuse contained in battery harness. Turn TEST key to TEST position. Wait 3-4 minutes for light to come on. Turn back to ON position, remove key and add remaining security screws.

If after two nights the luminaire fails to turn on proceed with the following:

1. Open luminaire by removing security screws and hinged unit to open position (Step 8) Using multi-meter set for voltage DC, check across two batteries (positive and negative terminals). Voltage should read between 11.5 and 14 Volts.
2. After 5 minutes, using multi-meter check PV voltage by probing the PV terminals that connect to the controller (near Molex connectors) with key switch in ON position. PV voltage should be equal to battery voltage.
3. If PV voltage remains at approximately 20 Volts for more than 30 seconds, check all PV connections and repeat. Ensure PV wire harnesses are connected with properly polarity (indicated by "+" and "-" labels on each conductor).
4. If problem persist consult Troubleshooting Guide or call SOL Inc at 800.959.1329 option 3.

GENERAL MAINTENANCE

How to Care for your Transit Shelter Security Light System

Solar Panel Cleaning

1. Once every three months the solar panels should be cleaned to insure optimum performance.
2. With a damp cloth thoroughly wipe down the solar panel removing any dirt and grime that may have accumulated.
3. Dry the solar panel with a soft clean cloth and repeat if necessary.



Caution! During the day solar panels can become extremely hot.

Fuse Replacement

1. Periodically, the fuse used to protect the system circuitry may have to be replaced.
2. To replace the fuse turn the system disconnect to the "off" position.
3. Remove the fuse cover, remove the existing fuse, insert the new fuse, and replace the fuse cover.
4. Turn the system to the "on" position.
5. Make sure that the replacement fuse matches the specifications of the original fuse. One spare has been provided with your system.

LED Fixture Replacement (LEDs last 15+ years)

1. Turn the system disconnect to the "off" position.
2. Remove the fixture and replace with a new one.
3. Turn the system disconnect to the "on" position.
4. Push the white "test" button to make sure the system is working properly.

Battery Replacement (batteries are designed to last 5 years)

1. Turn the system disconnect to the "off" position.
2. Remove the battery harness from the old batteries and place on the new batteries (all must be replaced at once).
3. Turn the system disconnect to the "on" position.
4. Push the white "test" button to make sure the system is working properly.

Troubleshooting

PROBLEM	POSSIBLE CAUSE	SOLUTION
The light does not turn on at all.	1. The battery is discharged.	1. Charge the battery.
	2. The battery is bad.	2. Replace the battery.
	3. The LED fixture is bad.	3. Replace the LED fixture.
	4. The fuse is blown.	4. Replace the fuse.
	5. The controller is bad.	5. Check the controller.
The light turns on at dusk but does not turn on again at dawn (split run time).	1. The run time exceeds the maximum run time for your model and location.	1. Contact SOL for assistance.
	2. Low battery voltage caused by inclement weather.	2. Allow for two to three days of consecutive sunny weather to charge the battery pack.
	3. Low battery voltage caused by shading of the solar panel.	3. Clear tree branches and other obstructions from the vicinity of the solar panel.
	4. The batteries are bad.	4. Replace all three batteries
The red LED on the controller remains illuminated.	1. Low battery voltage caused by inclement weather.	1. Allow for two to three days of consecutive sunny weather to charge the battery pack.
The light does not operate every day.	1. Low battery voltage caused by shading of the solar panel.	1. Clear tree branches and other obstructions from the vicinity of the solar panel.
	2. The batteries are bad.	2. Replace all four batteries.
The fuse blows repeatedly.	1. There is a short circuit in the wiring.	1. Check all system wiring for a short circuit.

In-Warranty Service Instructions

A Returned Merchandise Authorization (RMA) number must be obtained from SOL Inc before equipment can be returned for repair or replacement under warranty. To obtain an RMA, simply send an e-mail to: rma@solarlighting.com. Be sure to include the information outlined below.

We require the following information before we can issue an RMA number:

- Work order of the product being returned (located inside the upper section of light assembly)
- A description of the problem
- The address to which the repaired or replaced product is to be shipped

Equipment being returned must be properly packaged to protect it from damage during shipment. Shipping costs and insurance to SOL Inc are the responsibility of customer.

Upon verification of failure due to defects in materials or workmanship, we will either repair or replace the product at our discretion. The customer will be responsible for all shipping and handling charges for any equipment that is sent to SOL Inc in error (no definable problems).

SOL FivePlus™ Warranty

SOL Inc. is an ISO 9001:2008 certified worldwide manufacturer that designs and manufactures its own products. Although the best scenario involves never having to actually use a company's warranty, we are proud to offer, what we believe is the BEST WARRANTY available in the industry, from a company that has been in business since 1990.

SOL warrants each new lighting system to be free from defects in materials and workmanship and to perform under normal use and service. SOL will, at its option, repair or replace any system or system component that is defective in materials or manufacture within a minimum of five (5) years after purchase. Additionally, specific items within SOL's system have extended warranty protection as defined below:

<u>Item</u>	<u>Period</u>
PV Module (mono/polycrystalline)	20 Years
Thin Film PV Module(s)	10 Years
Mounting Hardware	20 Years
LED Luminaire	5 Years
Fluorescent Ballast	2 Years
Wire Harnessing	10 Years
Charge controller & LED Driver	5 Years

Batteries provided by SOL have a limited warranty providing for battery replacement from the date of shipment, with the following pro-rated coverage:

- 0 to 2 years: 100% credit (user pays 0% of the replacement battery price)
- 2 to 3 years: 60% credit (user pays 40% of the replacement battery price)
- 3 to 4 years: 40% credit (user pays 60% of the replacement battery price)
- 4 to 5 years: 20% credit (user pays 80% of the replacement battery price)

SOL's liability on any claim for damages arising out of or in connection with the manufacture, sale, installation, delivery or use of the unit shall not exceed the purchase price of the system. The purchaser assumes and will hold harmless SOL in respect of all such loss.

For warranty information on SOL products please call +1 (772) 286-9461. Before returning any product or component to SOL, first obtain a Return Material Authorization (RMA) number and return requested items via prepaid shipping. Failure to do so may result in no issued credit, and SOL shall not be responsible for said items.

This warranty does not cover damage or malfunction, as determined by SOL's service technicians or engineers, due to abuse, misuse, incorrect installation or accident such as, but not limited to:

- Use of incorrect mounting hardware
- Failure to follow operating and installation instructions provided by SOL
- Failure to maintain & operate the equipment in accordance with all applicable safety standards and codes
- Failure to maintain & operate the system under SOL Inc specified operating conditions
- Vandalism, theft, fire, flood, "Acts of God", and other problems beyond the control of SOL
- Unauthorized or improper repairs or adjustments
- Labor costs to remove, service, troubleshoot and/or reinstall all or part of SOL systems, unless previously agreed to and authorized IN WRITING by SOL Inc. by either the Customer Service Manager, Quality Manager or CEO
- Equipment service, rental, and or tools required to remove, service, troubleshoot, and/or reinstall all or part of SOL systems, unless previously agreed to and authorized IN WRITING by SOL Inc by either the Customer Service, Manager, Quality Manager, or CEO
- Equipment not provided by SOL Inc. and components and equipment external to the SOL Inc. system
- The cost of repairing or replacing property other than the SOL Inc. system

The use of electrical components, hardware, fixtures or batteries not provided by SOL Inc. voids this warranty. This warranty is in lieu of all other express warranties and the implied warranty of merchantability and is limited to terms of this written warranty. This warranty grants you specific legal rights, and you may have other rights that vary from state to state.



Reliable. Renewable. Remarkable.

SOL Inc | 3210 SW 42nd Avenue | Palm City, Florida 34990

www.solarlighting.com

E-mail support: support@solarlighting.com

Phone: +1.772.286.9461 | Toll: 800.959.1329 (USA & Canada)

Fax: +1.772.286.9616

Office Hours: Monday - Friday: 8:30am to 5:00pm (EST)

© 2010 SOL Inc. All rights reserved