

# Transit Shelter Ad & Security Light Solar Lighting for Back-to-Back Style Series



Installation and  
Owner's Manual

**Sol**<sup>®</sup>   
Reliable. Renewable. Remarkable.



# CONTENTS

<b>1.0</b>	<b><i>Introduction</i></b>	
1.1	Safety Instructions	4
1.2	Important Notes and Warnings	4
1.3	Operational Principles	4
<b>2.0</b>	<b><i>General Information</i></b>	
2.1	Site Selection	5
2.2	Unpacking and Inspection	6
2.3	System Specifications	6
2.4	System Overview	7
2.5	Tools Required	7
<b>3.0</b>	<b><i>Installation</i></b>	
3.1	Installing Solar PV Arrays (using PV Panels)	8
3.2	Attaching Angles	8
3.3	Attaching Solar Array Mounting Legs (Barrel Roof)	9
3.4	Attaching Assembly to Roof (Barrel Roof)	9-10
3.5	Harness Solar Array Mounting Angles (Peak/Flat Roof)	10-11
3.6	Solar Array Panel Mounting Details	12
3.7	Installing ThinFilm Solar Arrays	13
3.8	Routing PV Harness into Ad Kiosk	14-15
3.9	Installing LED Lightbar	16
3.10	Installing the LED Security Light	16
3.11	Installing Controller Plate and Batteries (Kiosk Base)	17
3.12	Installing Battery Enclosure and Batteries (Option)	17
3.13	Harness and Wiring Connections	18
3.14	System Activation	18
3.15	System Wiring	19
<b>4.0</b>	<b><i>Start Up / Operation</i></b>	
4.1	What to Expect from the System	20
4.2	Important System Issues	20
4.3	Special Features	20
<b>5.0</b>	<b><i>General Maintenance</i></b>	
5.1	How to Care for your Shelter Ad Light System	21
5.2	Troubleshooting	22
5.3	In-Warranty Service Instructions	22
5.4	SOL FivePlus™ Warranty	23

## 1.0 Introduction

### 1.1 IMPORTANT SAFETY INSTRUCTIONS - SAVE THESE INSTRUCTIONS



*This manual contains important instructions for the Transit Shelter Ad and Security Lighting system that shall be followed during installation and maintenance of the charge controller.*

The SOL Transit Shelter Ad and Security Lighting system is a patented, off-grid, standalone, solar-powered lighting system. Years of engineering, development, and testing ensure that this system meets or exceeds all performance and reliability specifications. Every system that leaves our factory has been quality control tested and inspected to assure you of an easy installation and highly dependable performance. All mechanical fittings and electrical connections are designed for simple and reliable installation. The system is ready for use immediately after the components are mounted and the plug and play connectors are joined.

### 1.2 IMPORTANT NOTES AND WARNINGS

This installation and instruction manual provides installation, operation, and maintenance instructions for the SOL Transit Shelter Ad and Security Lighting system. The entire contents of this manual should be thoroughly reviewed and understood prior to installing this equipment. Do not discard this manual. It contains complete maintenance instructions, a troubleshooting chart, and a spare parts list. To insure proper operation of this equipment, it is important that the equipment be utilized for its intended use. Any use of this equipment for purposes other than those intended will void all warranties.



*Installation and/or troubleshooting should be performed only by qualified personnel. Follow local codes at all times during installation of the SOL Transit Shelter Ad and Security Lighting system.*



*Be very careful when working with batteries.*



*Do not allow bare ends of the wires to touch each other or grounded metal parts while connected to the controller(s). This will damage the controller(s).*

### 1.3 Operational Principles

The SOL Transit Shelter Ad and Security Lighting system is designed to provide reliable operation and illumination all year. The solar array (the photovoltaic panel, or PV panel) re-charges the battery (or batteries) each day, replacing energy that was used during the previous evening so that illumination can again be provided during the following evening. The system is designed with a reserve, so that regular illumination will continue to be provided during periods of rainy or cloudy weather. The controller monitors battery condition and will shut off illumination if the battery charge drops below a specified level. This may occur if there is a prolonged rainy or cloudy weather or if the solar array is shaded during part of the day. The controller automatically restarts the system when the condition is corrected and the battery charge returns to the specified level, protecting the batteries.

## 2.0 GENERAL INFORMATION

### 2.1 Site Selection and Preparation

Locate and install the PV panels in an area where the PV panels can face the equator (due south in the Northern hemisphere) and not shaded by trees, poles, buildings, or other objects during the day (Figure 1).

Do not locate in an area where there is excessive ambient or reflected light at night which may simulate daylight and cause the system controller to turn off the system. Installing in a location where the solar panels are shaded during part of the day will prevent the solar panel from fully charging the battery, reducing the hours of nighttime illumination and possibly damaging the battery.



*Note: If system is installed near a tree, check the tree branches every three months and trim when needed.*

**IMPORTANT: Proper alignment for maximum charging of the pv panels requires that the panels face south, however under some circumstances, the pv panels may only be able to face west because of shelter location. Please notify SOL immediately so that the panels can be sized accordingly.**

Installation of the solar light system must comply structural engineering requirements for local and national codes.

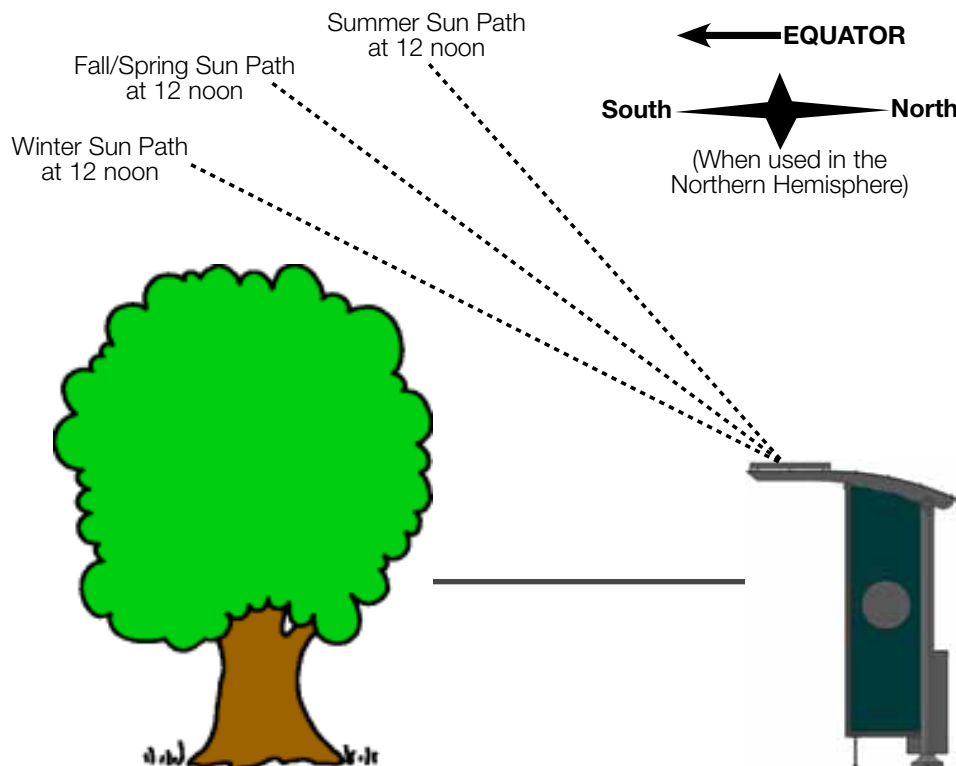

**FIGURE 1** LOCATING AND POSITIONING THE PV PANELS

## 2.2 Unpacking and Inspection

The SOL TSAL Security Light System is shipped as a complete kit. Prior to assembly, remove the entire contents of the kit from the packaging and check the contents of the kit against the Parts List (Table 1). For full details refer to Shipping Forms.

Please call SOL Customer Service at +1-772-286-9461 if any components or hardware are missing.

DESCRIPTION	PART NUMBER
Solar Panel Assembly (PV Panel or ThinFilm)	33172-015 or 33173-003
Solar Panel Mount (for PV Panel)	63000-001
Battery 12V 33aH	86007-002
Solar Panel PV Harness	892006-005
12-LED UniLight Lightbar	973012-100
UniLight Harness	833096-100
2-LED Security Lightbar (optional)	951204-004
Security Light Harness	892006-008
Battery Harness	802010-100
Triple Harness	802030-100
Controller	80004-001
Mounting Hardware	TEK14X100
PV Panel Hardware	TEK 14 x150
Lightbar/Security Light hardware	TEK 8X.50
Reflector side	650070-002
Reflector bottom	650070-004

**TABLE 1** PARTS LIST

## 2.3 System Specifications

ITEM	DESCRIPTION
Solar Panel / ThinFilm	<i>Poly-crystalline, Framed, with high-transmission 3mm tempered glass cover / Flexible, Amorphous silicon with butyl adhesive coating</i>
Solar Panel Mounting Assembly	<i>Architectural Angle Aluminum Mounting Legs</i>
Battery	<i>NRGLife™ - Sealed, No-maintenance, Gel Cell Lead Acid</i>
Battery Charge Indicator	<i>Single green LED indicates charging. Single red LED indicates load present/low voltage disconnect.</i>
Power Management	<i>Solid-state charge controller with low voltage disconnect (LVD)</i>
Hardware	<i>Stainless steel, tamper resistant</i>
Illumination Technology	<i>SOL UniLights</i>
Illumination "On" Time	<i>System Dependent</i>
Minimum Autonomy	<i>5 days</i>
Operating Temperature	<i>-30°C to + 80°C (-22°F to + 176°F)</i>
Weight	<i>Varies With Unit Size</i>

**TABLE 2** SYSTEM SPECIFICATIONS

## 2.4 System Overview

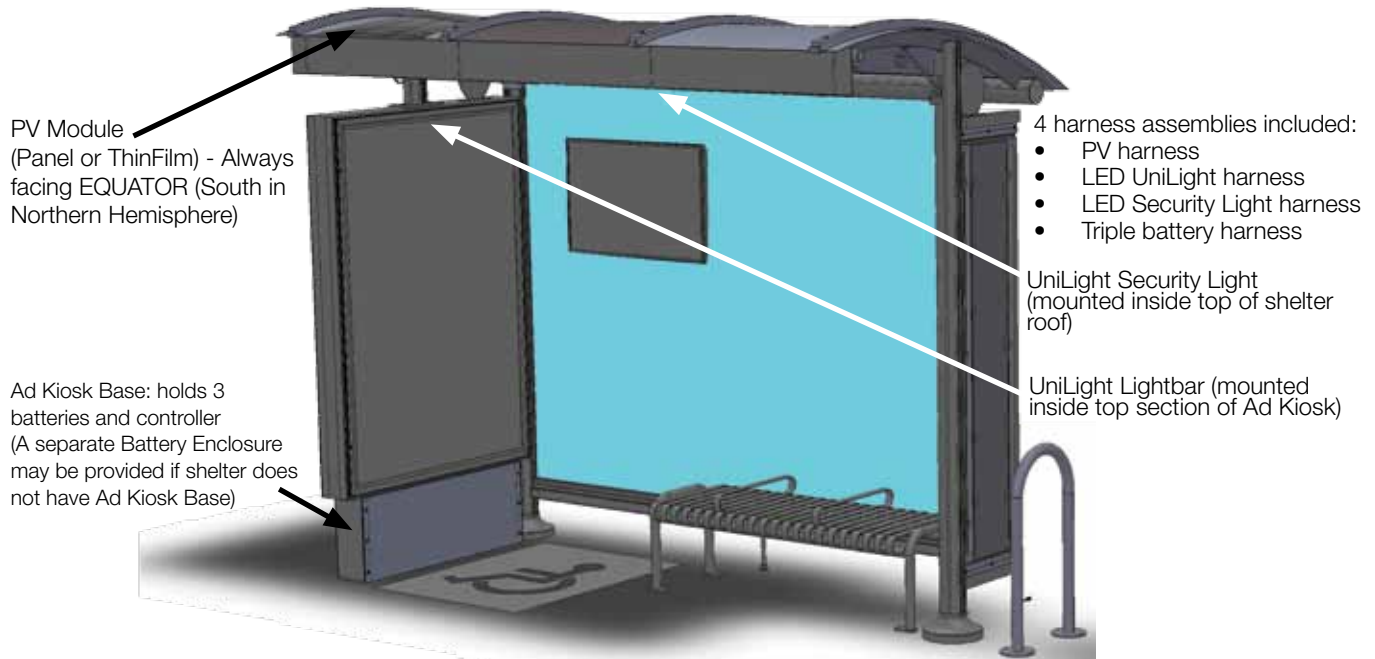

**FIGURE 2** SYSTEM OVERVIEW

## 2.5 Tools Required

The following tools are recommended to install the Transit Shelter Solar Light System.

- Phillips screwdriver
- Flathead screwdriver
- Adjustable wrench
- Basic socket set
- 5/16" hex head driver
- Digital volt meter (optional)

## 3.0 INSTALLATION

### 3.1 Installing the Solar PV Arrays (using PV Panels)

1. Lay the solar array(s) on a protected surface with the solar array junction box toward you. The cardboard shipping carton can be used to provide a protected surface while you install the mounting angles.
2. Depending on the solar array size of your system, there may be one, two, or three solar panels per shelter. Make sure to check your array size.
3. There should be one PV harness per shelter with corresponding mc connectors for each solar array.

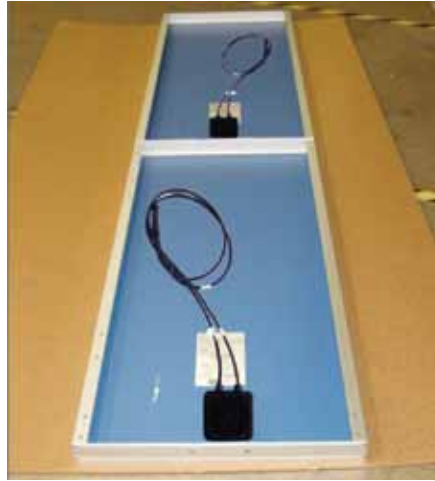

**FIGURE 3** SOLAR ARRAY SYSTEM

### 3.2 Installing the Solar PV Arrays and Attaching Angles (using PV Panels)

1. Do not place screws in the areas where the solar array mounting legs will be placed. Place the solar array mounting angles on the edge of the solar array, so that the bottoms and sides of the solar array are covered, as in Figure 4.
2. Make sure the pre drilled holes in the mounting angle are on the sides of the solar array. Center the solar array so that there are equal reveals of the mounting angle on each end of the array.
3. Using the #14 X 1" TEK screws provided, attach the mounting angles to the solar array.  
*Do not place screws in the areas where the solar array mounting legs will be placed.*

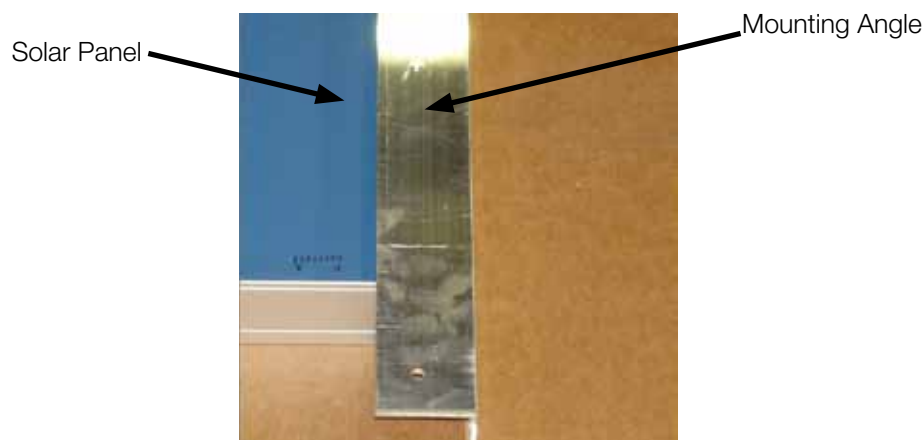

**FIGURE 4** SOLAR PANEL MOUNT

### 3.3 Attaching the Solar Array Mounting Legs (for Barrel Roof)

1. Measure the distance between the roof ribs of the shelter to determine the placement of the solar array mounting legs. Ensure that the panel is mounted on the surface most facing towards the equator or due South in the Northern hemisphere.
2. Mark the position of the roof ribs on the solar array mounting angle.
3. Using the #14 X 1" TEK screws provided, attach the solar array mounting legs to the solar array mounting angle as shown.
4. If the solar array is 22" or less in width, the short leg of the mounting leg goes against the solar array mounting angle. (As seen in Figure 5.)
5. If the solar array is greater than 22" in width, the long leg of the mounting leg goes against the solar array mounting angle.
6. The solar array assembly now is ready to be placed on to the shelter roof.

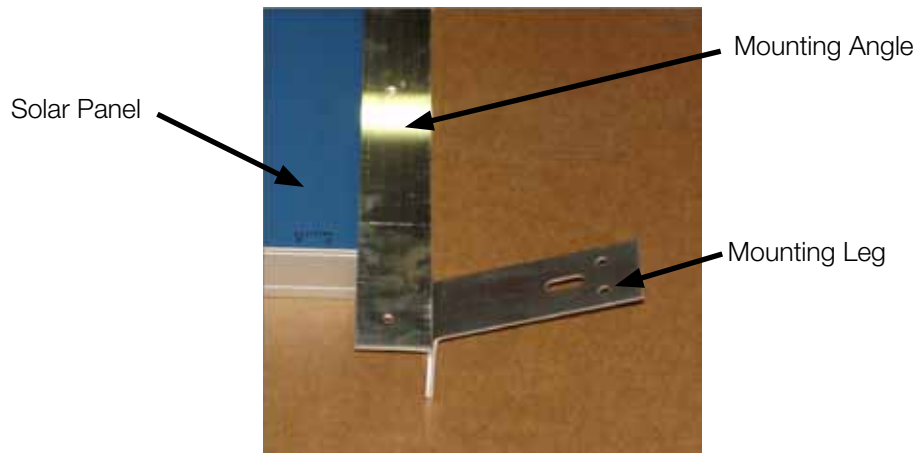

**FIGURE 5** ATTACHING MOUNTING LEG TO ANGLE

### 3.4 Attaching the Solar Array Assembly to Shelter Roof (for Barrel Roof)

1. Before mounting the solar array to the roof, determine the wire path of the PV harness. It will need to go through the roof and into the ad kiosk.
2. Once the wire path has been determined drill a 3/4" hole in the shelter roof for the PV load cable and a 7/8" hole into the ad kiosk roof for the wire seal tight. The shelter roof hole should be located under the solar array to help keep water out.
3. Connect PV harness with each solar panel. Depending on the number of panels, the PV harness will have the corresponding mc connectors for each panel ie 2-panel system has double mc connectors.
4. As you place the solar array assembly on the roof of the shelter, drop the PV harness down through the 3/4" shelter roof hole.
5. Using the #14 X 1 1/2" TEK screws, attach the solar array assembly to the shelter. It may be necessary to remove and replace one of the existing shelter roof rib screws for proper mounting.

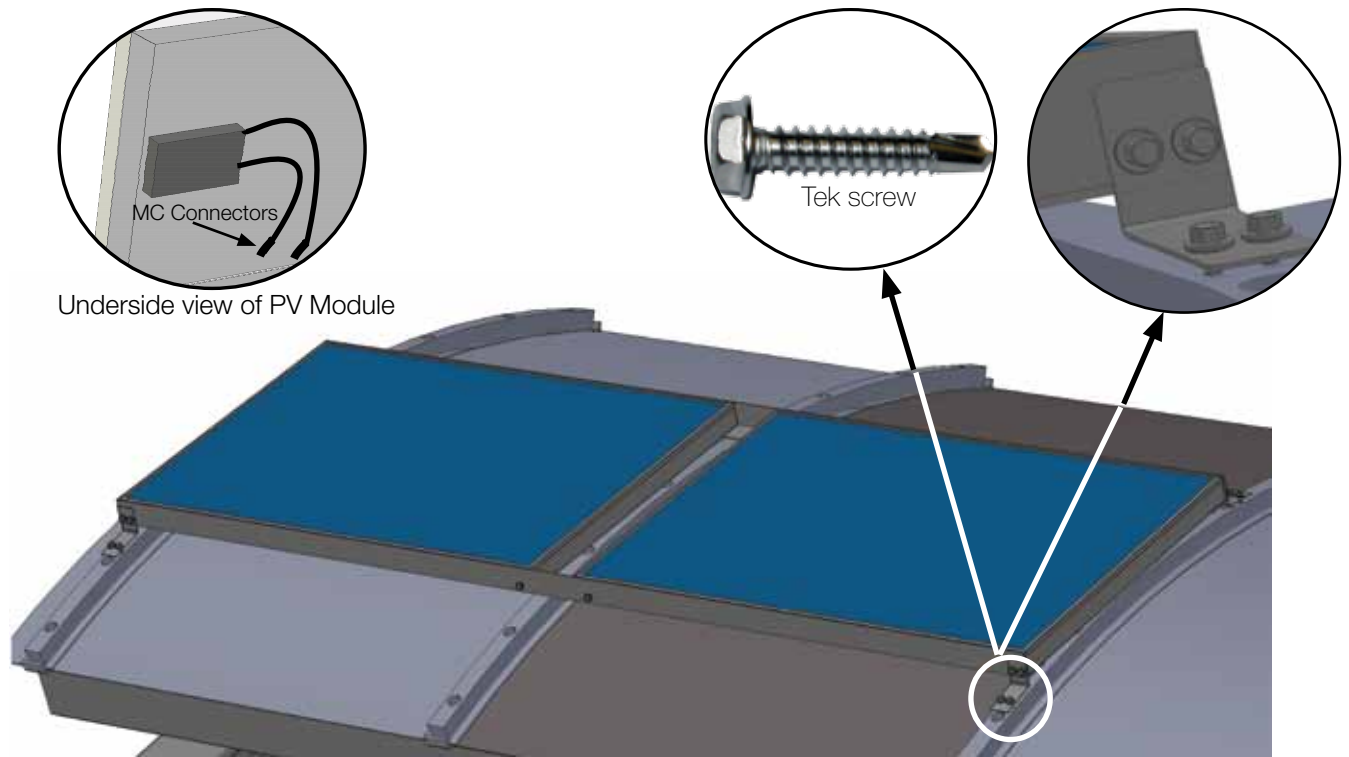

**FIGURE 6** ATTACHING SOLAR ARRAY ASSEMBLY TO SHELTER

### 3.5 *Attaching the Solar Array Mounting Angles (for Peak or Flat Roof)*

1. If mounting using existing captive hardware on shelter roof, then determine the best place to secure the solar array(s) by centering the solar array mounting angles along the ribs of the shelter roof ensuring the holes line up to match captive hardware already securing the roof (Figure 7) and that the solar arrays will fit securely within the mounting angles. Ensure that the panel is mounted on the surface most facing towards the equator or due South in the Northern hemisphere.
2. Loosen each of the captive hardware screws or nuts on the shelter roof and place mounting angles in designated position and reattach the screws or nuts to secure the mounting angles to the shelter roof.

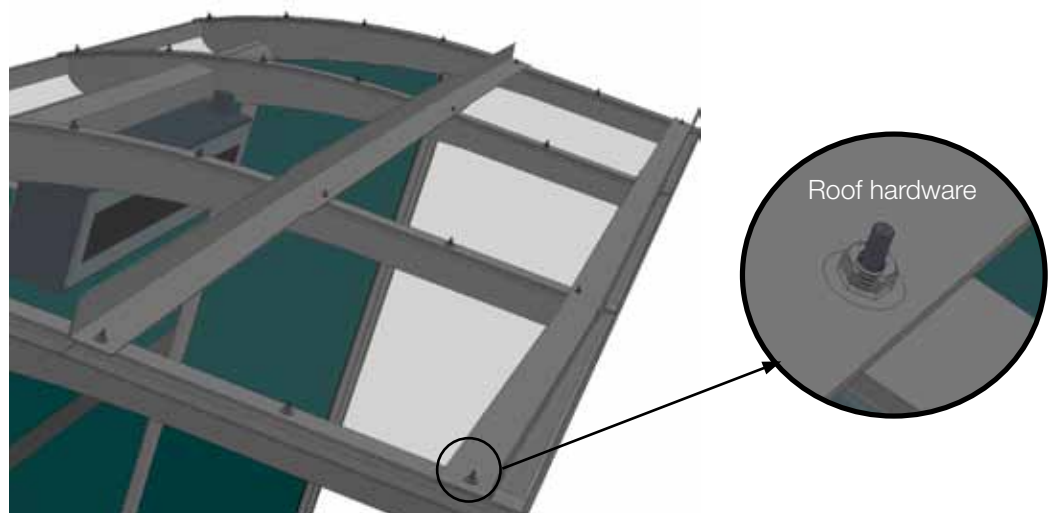

**FIGURE 7** SECURING PV ANGLES TO ROOF RIBS

3. If mounting directly to shelter roof using the TEK screws, measure the distance between the roof ribs of the shelter to determine the placement of the solar array mounting legs. Ensure that the panel is mounted on the surface most facing towards the equator or due South in the Northern hemisphere.
4. Mark the position of the roof ribs on the solar array mounting angle.
5. Fasten the mounting angles to the PV panel frame using 16 x #14 x 1" Tek screws provided. The PV panel(s) should be centered on the aluminum angles (Figure 8).

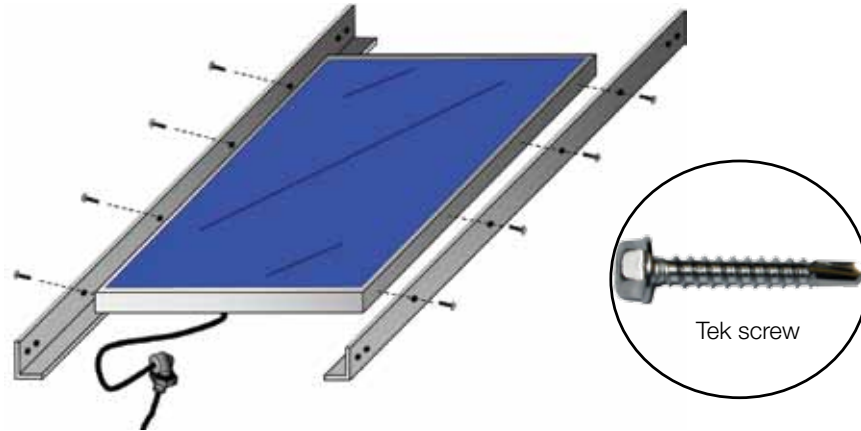

**FIGURE 8** MOUNTING PV ANGLES

6. Before mounting the solar array to the roof, determine the wire path of the PV harness. It will need to go through the roof and into the ad kiosk.
7. Once the wire path has been determined, drill a 3/4" hole in the shelter roof for the PV load cable and a 7/8" hole into the ad kiosk roof for the wire seal tight. The shelter roof hole should be located under the solar array to help keep water out.
8. Connect PV harness with each solar panel. Depending on the number of panels, the PV harness will have the corresponding mc connectors for each panel i.e. 2-panel system has double mc connectors.
9. As you place the solar array assembly on the roof of the shelter, drop the PV harness down through the 3/4" shelter roof hole.
10. Using the #14 X 1 1/2" TEK screws attach the solar array assembly to the shelter. It may be necessary to remove and replace one of the existing shelter roof rib screws for proper mounting (Figure 9).

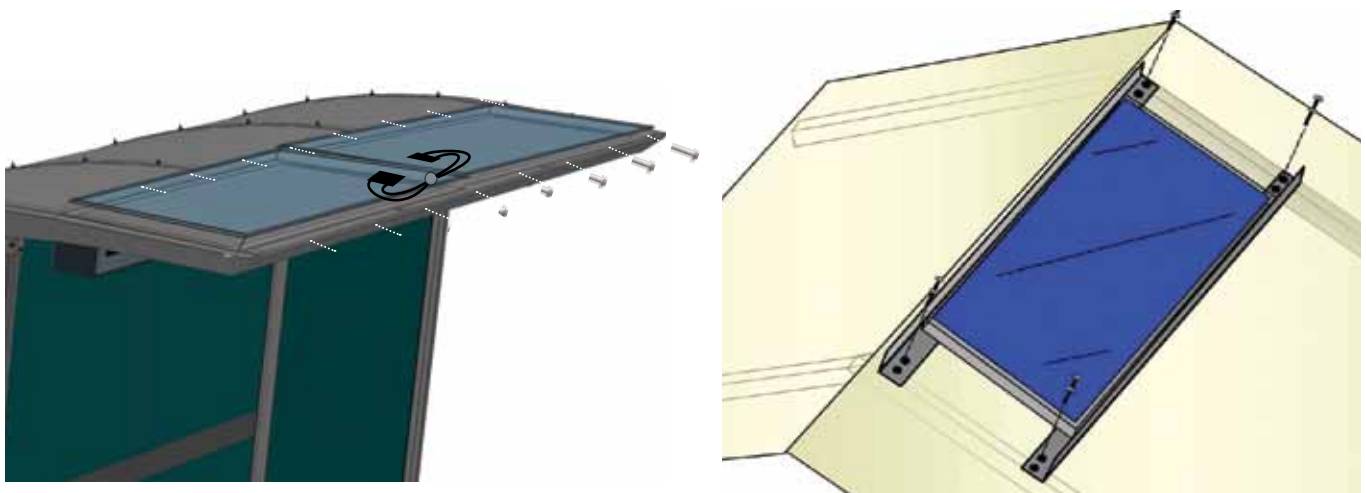

**FIGURE 9** MOUNTING PV ON SHELTER ROOF

### 3.6 Solar Array Mounting Details

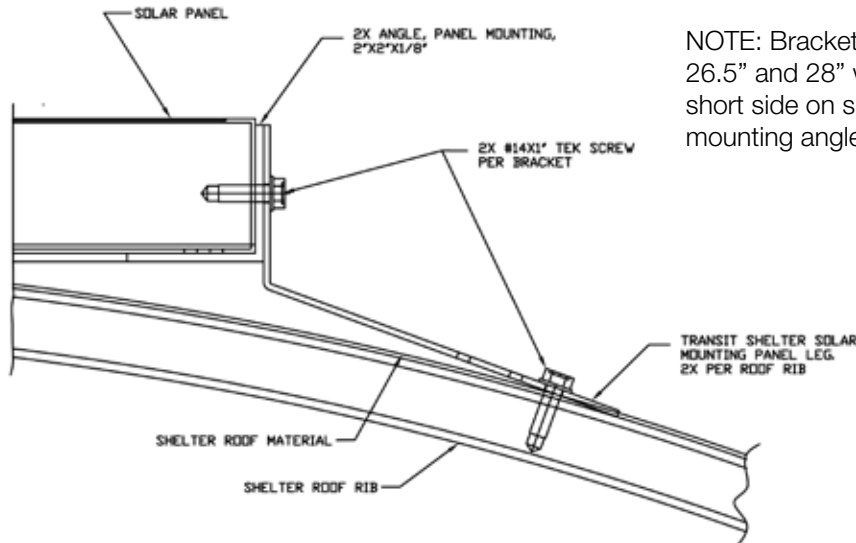

NOTE: Bracket orientation for 20" wide panels. For 26.5" and 28" wide panels, orient brackets with short side on shelter slat and long side on panel mounting angle.

**FIGURE 10** MOUNTING DETAIL FOR DOME ROOF

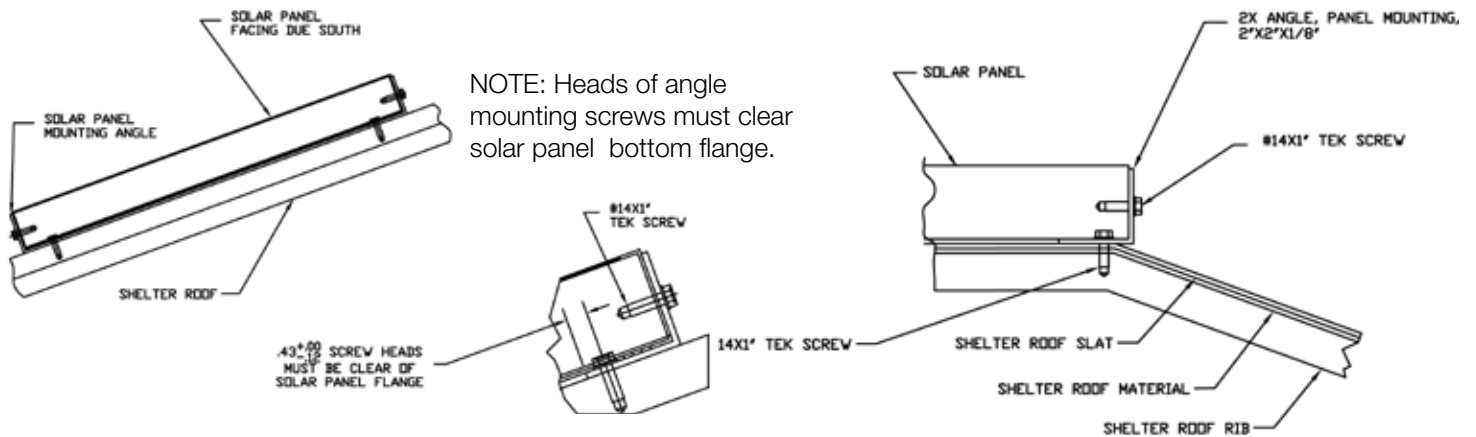

**FIGURE 11** MOUNTING DETAIL FOR PEAK ROOF

**FIGURE 12** MOUNTING DETAIL FOR MANSARD ROOF

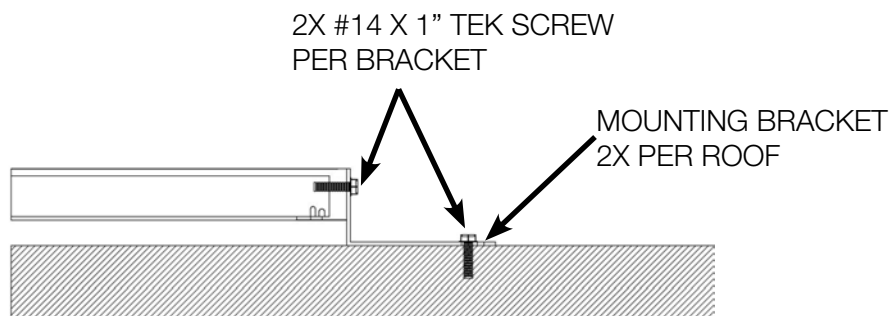

**FIGURE 13** MOUNTING DETAIL FOR FLAT ROOF

### 3.7 Installing ThinFilm on the Shelter Roof

1. Remove ThinFilm flexible solar array from packaging and place in desired horizontal surface of roof shelter to determine correct positioning. Ensure that the panel is mounted on the surface most facing towards the equator or due South in the Northern hemisphere.
2. Determine best route for PV harness to the upper section of the Ad Kiosk.
3. Connect flexible solar array MC type IV connectors to PV harness. Route PV Harness from shelter to upper section of light assembly (Figure 14).



**FIGURE 14** CONNECTING MC CONNECTORS

4. Carefully remove the protective film on the back of the flexible solar array and secure on roof shelter by gently pressing to adhere (Figure 15).

**WARNING: Butyl adhesive coating is designed for first time adhesion and should not be repositioned after adhering.**

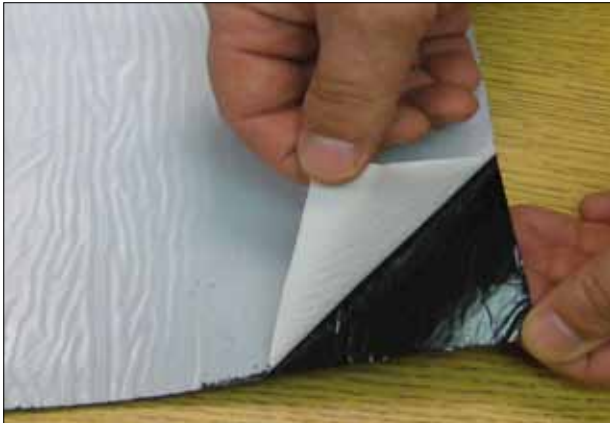

**FIGURE 15** REMOVING PROTECTIVE FILM



**FIGURE 16** ROUTING PV HARNESS

5. It is recommended that the PV harness be routed around shelter roof to upper section of ad kiosk and excess harness be discretely secured by clips or other method to ensure a neat installation of the ThinFilm panels(s) (Figure 16).
6. Alternately, a 7/8" hole can be drilled in shelter roof above upper light assembly to route harness directly and secure opening with elbow seal tight. Routing around shelter and securing the excess PV harness is the preferred method.

### 3.8 Routing PV Harness into Ad Kiosk

1. Route PV Harness from Solar Array into shelter structure. A 7/8" hole may need to be drilled into shelter structure to route the harness down structure and into the Ad Kiosk base. Ensure PV Harness is neatly secured on shelter roof - wire clips or other hardware may be used.



*Note: Some shelters may already have a pre-drilled access hole and plate for routing the PV harness into the shelter and down into Ad kiosk (Figure 19).*

2. Once PV Harness is routed into shelter structure and Ad Kiosk, secure with elbow seal tight.
3. Routing may vary depending on type of PV array ie ThinFilm may require routing of PV harness over top of shelter (Figure 18).

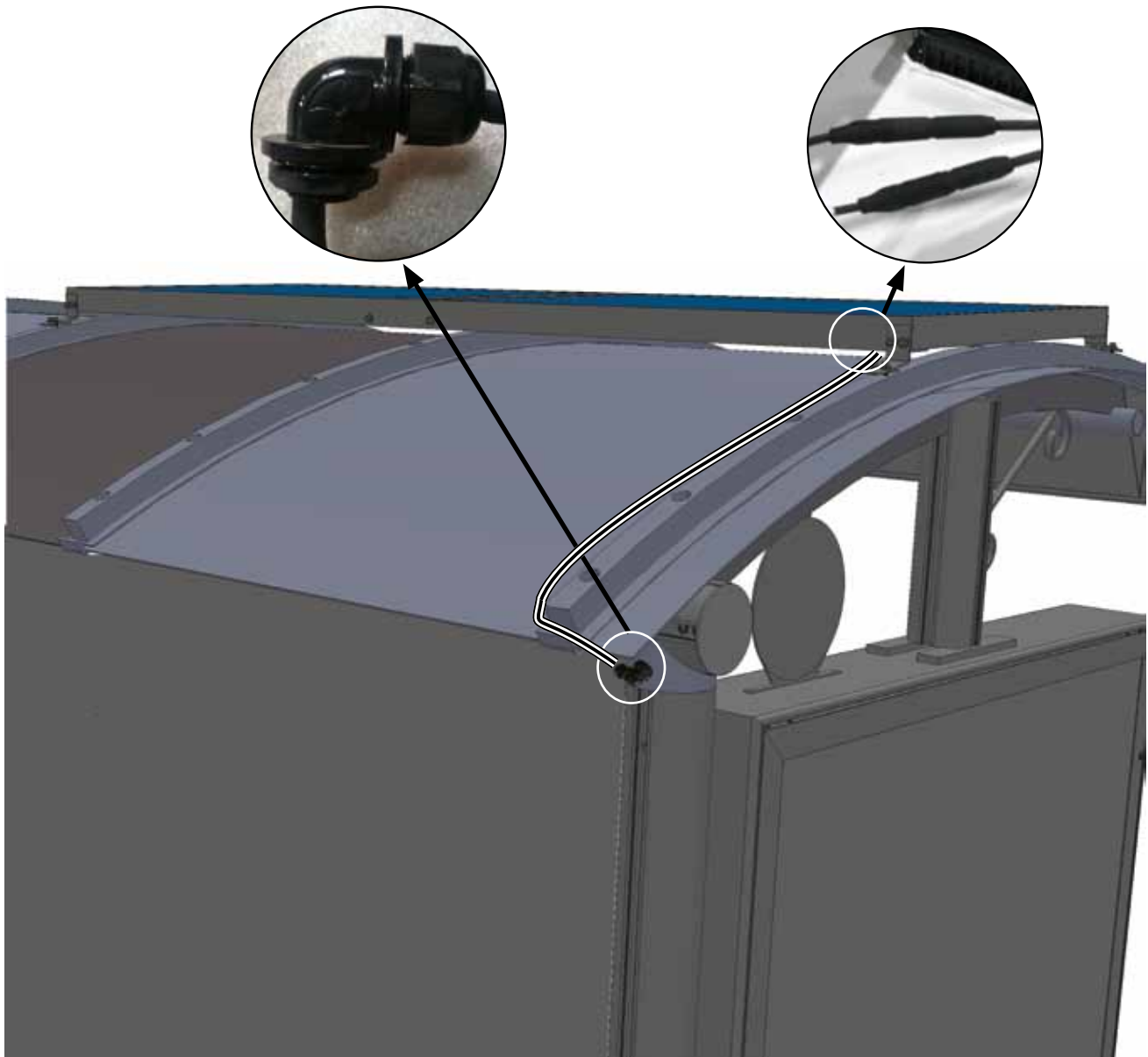

**FIGURE 17** ROUTING PV HARNESS FROM PANEL

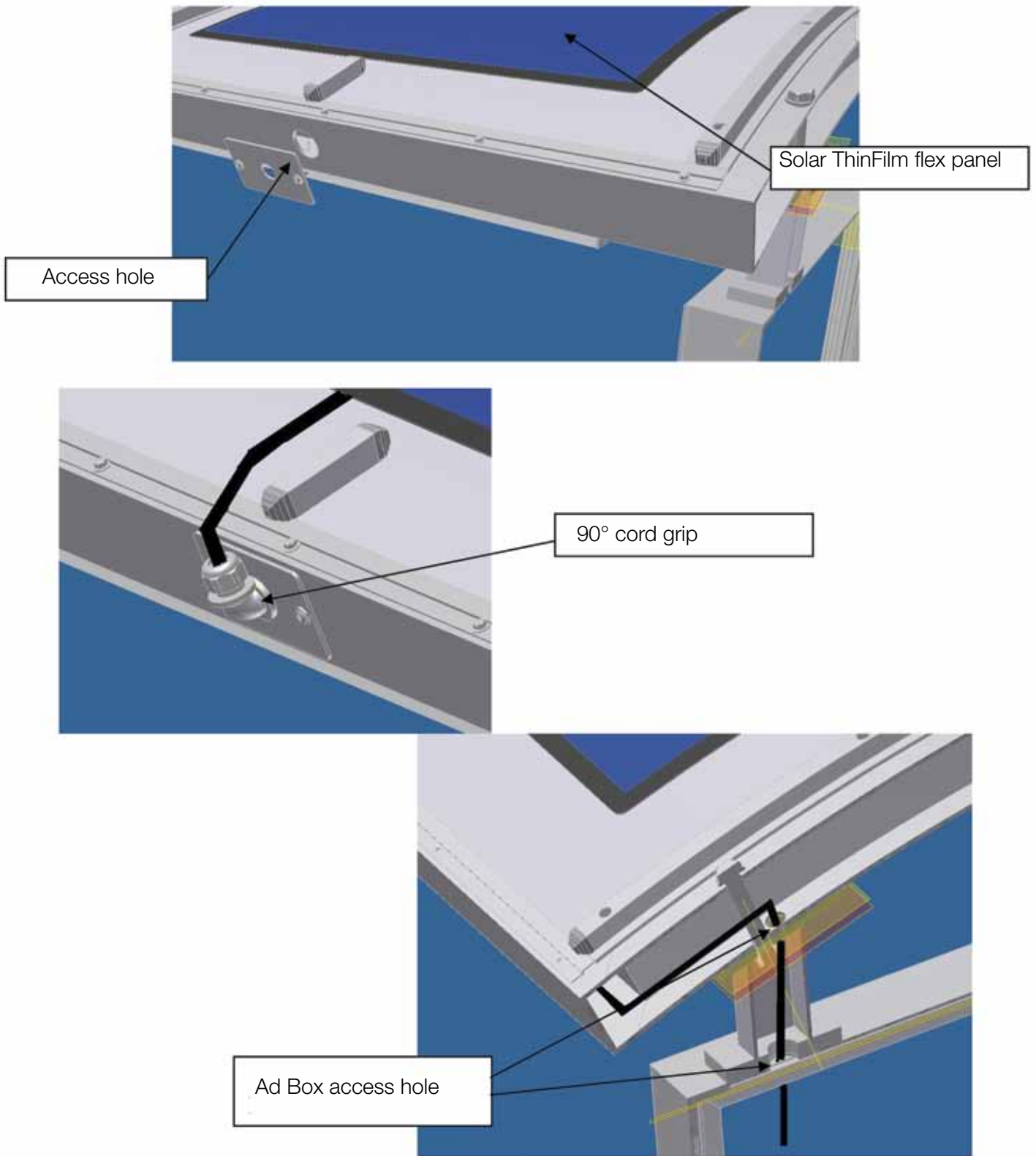

**FIGURE 18** ROUTING PV HARNESS FROM THINFILM

### 3.9 Installing LED Lightbar

1. Remove Lightbar from box and mount to top of Kiosk, center left to right.
2. Line brackets up with extrusion tabs, secure with small #8 X 1/2' TEK screws.
3. Connect Lightbar harness and run excess harness to bottom of ad kiosk.
4. After all wires are run, mount reflectors on each vertical side of kiosk. Line holes up with extrusion tabs and secure with small TEK screws.
5. Bottom reflector simply rests at the bottom of the ad kiosk. Peel protective plastic coating off reflector after installation.



**FIGURE 19** INSTALLING LED LIGHTBAR

### 3.10 Installing LED Security Light

1. Remove Security Light from box and mount to top of shelter roof (centered).
2. Line brackets up with roof ribs and secure with small #8 X 1/2' TEK screws.
3. Connect Security Light harness and route through conduit into ad kiosk. If conduit is not installed, harness should be routed inside shelter extrusion by drilling a small hole near top of ad kiosk.
4. Keep exposed harness neatly secured to shelter roof ribs using wire ties/clips.

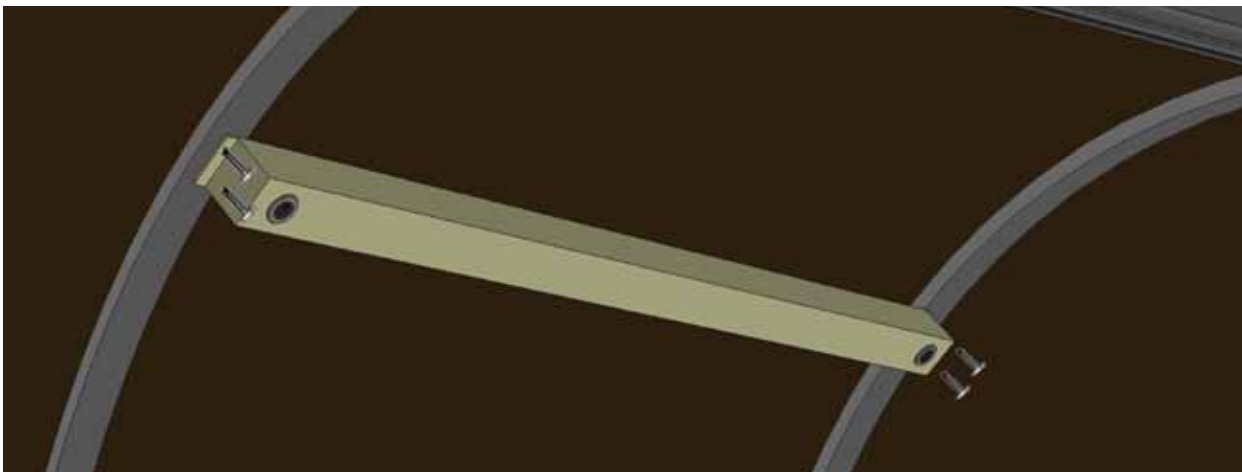

**FIGURE 20** INSTALLING LED LIGHTBAR

### 3.11 Installing Controller Plate and Batteries (inside Kiosk base)

1. The controller is shipped pre-wired and is secured to a mounting plate.
2. Open battery storage area by unscrewing the cover plate from the ad kiosk base inside the shelter.
3. Place batteries parallel inside storage area enclosure.
4. Bolt control plate to top or side of battery storage area with bolt sets provided.

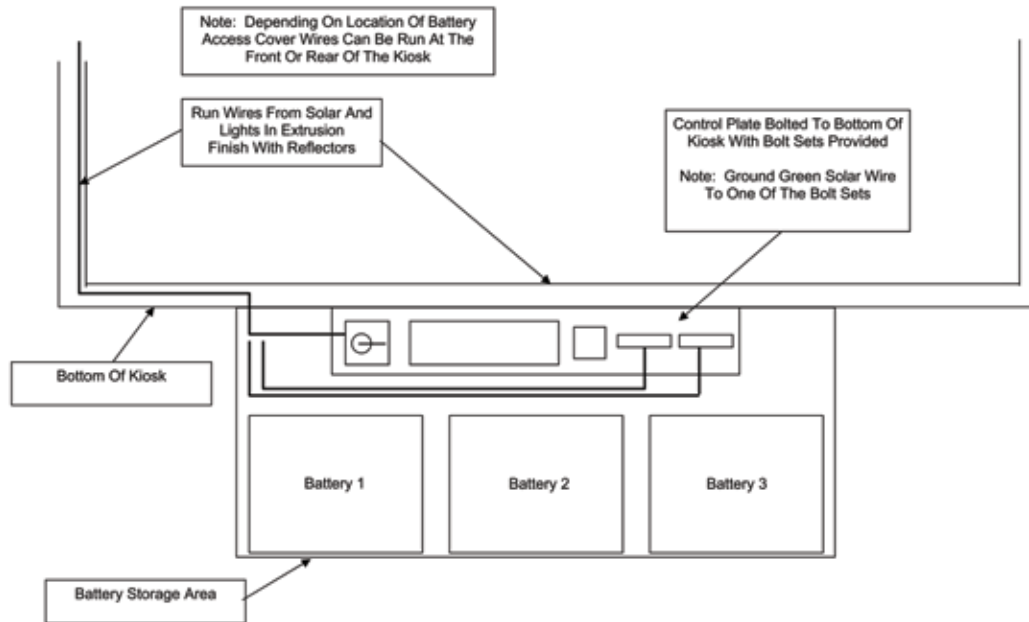

**FIGURE 21** INSTALLING CONTROLLER AND BATTERIES

### 3.12 Mounting Battery Enclosure and Installing Batteries (with separate battery enclosure)

1. A battery enclosure mounting bar should already be attached to shelter. If a mounting bar has not been provided, please contact SOL Inc.
2. Remove Battery Enclosure screws from cover and place Battery Enclosure (pre-drilled) on mounting bar and secure with security screws (Figure 22).
3. Place each battery on shelf.

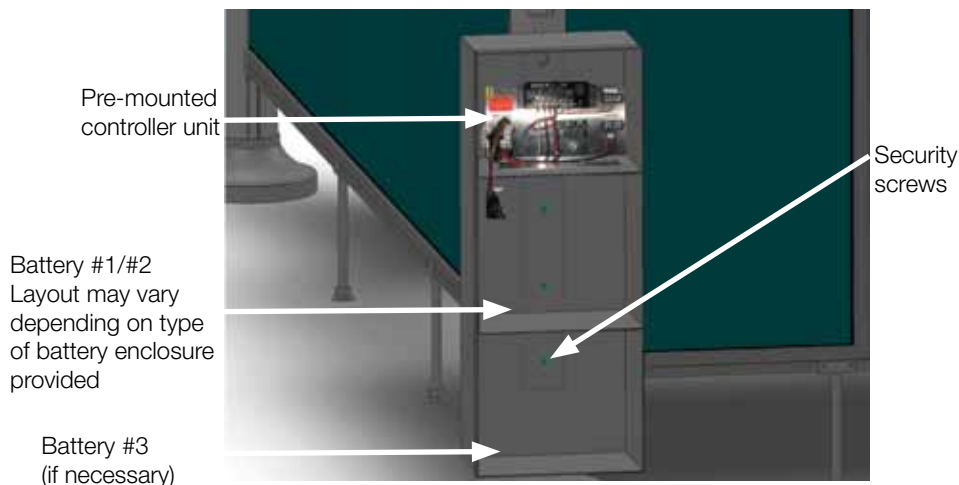

**FIGURE 22** INSTALLING CONTROLLER, BATTERY ENCLOSURE AND BATTERIES

### 3.13 Harness and Wiring Connections

1. The Transit Shelter Ad and Security Lighting kit, typically comes pre-wired from the factory.
2. The PV Harness (from the solar array), however, once inside the Battery Enclosure/Battery Storage Area in Ad Kiosk, needs to be wired to the system disconnect and the Lightbar and Security Light harnesses needs to be wired to the Lightbar and Security Light terminal strips.
3. Refer to the wiring diagram and labeling on the system disconnect and wire the PV harness to the system disconnect.
4. Refer to the wiring diagram and labeling on the LED Lightbar and wire the LED Lightbar wires to the terminal strip.
5. Refer to the wiring diagram and labeling on the LED Security Light and wire the LED Security Light wires to the terminal strip.
6. For each battery, loosely connect the battery harness to the battery terminals (Figure 23). When connecting the battery to each battery harness, connect the positive terminal first (Red +). Protect the free (unconnected) ends of the battery harness from touching other metal parts so they will not accidentally cause a short. Tighten the connection on both terminals. Cover positive terminal with red battery boot. Repeat for each battery.
7. Connect the triple (or quad) harness to each of the battery harnesses as per the wiring diagram.
8. Connect the battery harness to battery plug coming from the disconnect.

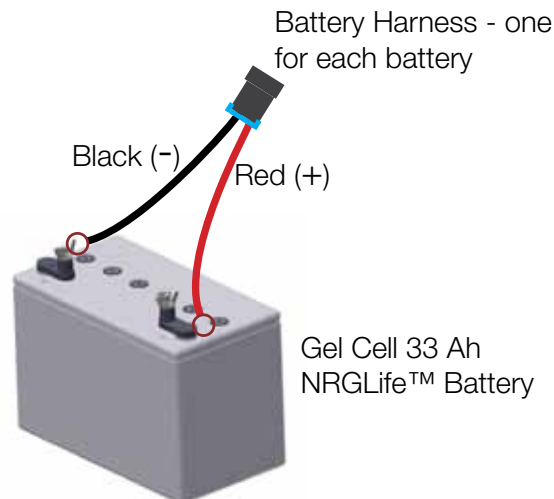

**FIGURE 23** BATTERY HARNESS

### 3.14 System Activation

1. Turn the system disconnect to the “on” position. The green charge light should be on at this time.
2. Press the white “test” button to check the system. The Ad Lightbar should come on for approximately five minutes then shut off.
3. Close the Battery Enclosure/Ad Kiosk cover. The system is now operational.

### 3.15 System Wiring

REV	Description	Date	APP
A	Initial Release		

PROPERTY OF SOLAR OUTDOOR LIGHTING, INC.  
 These drawings are the sole and exclusive property of Solar Outdoor Lighting, Inc., and shall not be used, reproduced, or disclosed to any third party for any purpose, without the prior written consent of SOL, Inc.

Solar panels wired in parallel.  
 Type of array and quantity may vary with installation.

Note: All internal wiring 12 ga. THHN Jacket.  
 All wiring conforms to Article 690 of the NEC.

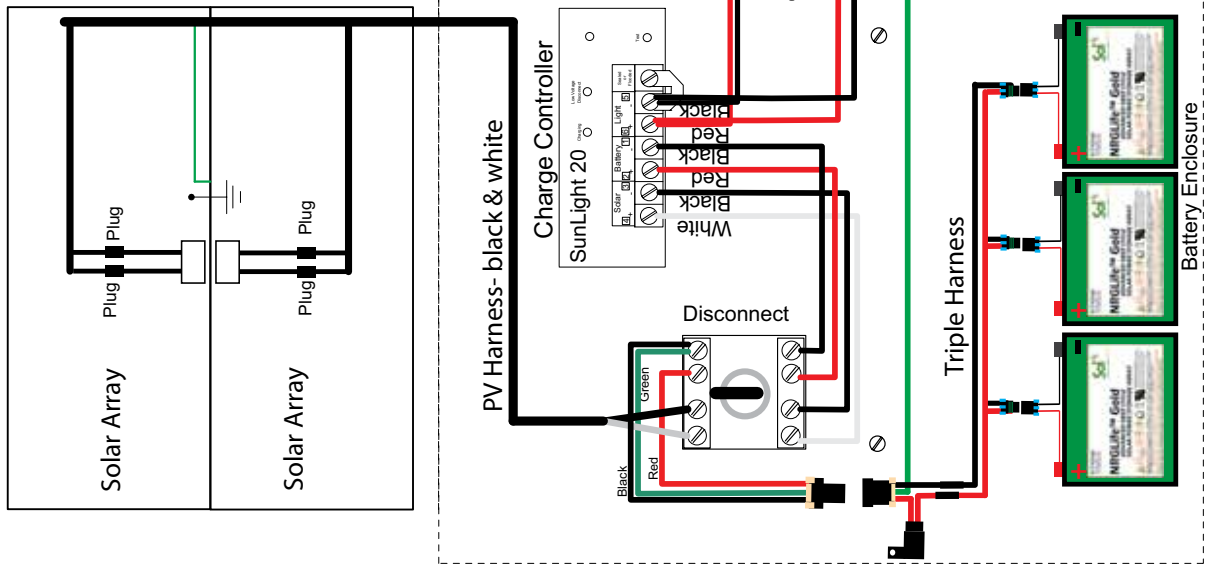

**SOL INC.**  
 3210 SW 42nd Ave, Palm City, FL 34990  
 Description: **TSAL-DTD-BTB-LED-SECURITY**

REV A

Sheet \_\_\_ of \_\_\_

## 4.0 START UP / OPERATION

### 4.1 What to Expect from the System

**Break In Period:** When first installed, your new system needs a “break in” period before it reaches maximum performance. This “break in” period will not affect the performance of the light unless the “break in” period is when the system is operating at its maximum limits. This would be the case if the system is installed in the winter months, or during a string of successive bad weather days.

**Battery:** A new battery will only accept approximately 85% of its rated capacity. It will achieve 100% of capacity in about 45 days.

**Charge Controller:** After a week of operation, the controller will have “learned” the system’s parameters and will achieve maximum efficiency.

The system should operate the first night, however it may require a full day of peak sun to reset all of the circuits and the system may not operate the night of installation.

### 4.2 Important System Issues

The SOL Transit Shelter Ad Lighting System is designed to operate reliably and provide ad shelter illumination all year long. During the day, the solar panel provides enough energy to charge the battery for operation of the LED Ad Light for the night that follows. The system is designed with a 5-night reserve charge; however, extended periods of low sun level may deplete this reserve affecting the performance of the system. The following conditions could cause your system not to operate to specification.

#### Prolonged Bad Weather

A series of days having low levels of sunlight may deplete the battery reserve. Depending on the severity of the condition, the nightly illumination period could be reduced until a sunny day re-establishes the battery’s charge reserve. Please note that the system may need anywhere from 2-10 (summer-winter) days of good sunny weather before the full 5-night battery reserve is completely achieved.

#### Shading

Installation of the system in a location where the solar panel is shaded during part of the day will inhibit the solar panel’s ability to fully charge the battery and may severely damage the battery. The hours of nighttime illumination would then be reduced by the system’s controller.

If the above conditions do not exist and the system does not function properly contact SOL.

### 4.3 Special Features

#### Battery Voltage Monitoring System

The system has a built in battery voltage monitoring system. The charge controller constantly monitors the voltage of the battery and the status of the battery can be checked by viewing the status of the red LED light on the charge controller. If the red LED low voltage indicator is not illuminated the battery voltage is in the normal operating range of 11.7-12.5 V. If the red LED low voltage indicator is illuminated the battery voltage has fallen below 11.7 V. and may have to be replaced.

*Note: The system also has a low voltage protection function as to not allow the system to drain the battery once low voltage has been detected. For example, the red LED low voltage indicator light may come on after a period of bad weather if the battery charge has fallen below 11.7 V. This does not necessarily mean that the battery pack needs to be replaced. After the bad weather has passed and 2-3 consecutive sunny days check the status of the red LED. If the red LED is not illuminated chances are the battery pack has recovered to the normal operating voltage range and is fine. If the red LED is still illuminated more than likely the battery needs to be replaced.*

## 5.0 GENERAL MAINTENANCE

### 5.1 How to Care for your Shelter Ad Light System

#### **Solar Panel Cleaning**

1. Once every three months, the solar panels should be cleaned to insure optimum performance.
2. With a damp cloth, thoroughly wipe down the solar panel removing any dirt and grime that may have accumulated.
3. Dry the solar panel with a soft clean cloth and repeat if necessary.



*Caution! During the day solar panels can become extremely hot.*

#### **Fuse Replacement**

4. Periodically, the fuse used to protect the system circuitry may have to be replaced.
5. To replace the fuse, turn the system disconnect to the “off” position.
6. Remove the fuse cover, remove the existing fuse, insert the new fuse, and replace the fuse cover.
7. Turn the system to the “on” position.
8. Make sure that the replacement fuse matches the specifications of the original fuse. One spare has been provided with your system.

#### **LED Fixture Replacement (LEDs last 15+ years)**

9. Turn the system disconnect to the “off” position.
10. Remove the fixture and replace with a new one.
11. Turn the system disconnect to the “on” position.
12. Push the white “test” button to make sure the system is working properly.

#### **Battery Replacement (batteries are designed to last 5 years)**

13. Turn the system disconnect to the “off” position.
14. Remove the battery harness from the old batteries and place on the new batteries (all three must be replaced at once).
15. Turn the system disconnect to the “on” position.
16. Push the white “test” button to make sure the system is working properly.

## 5.2 Troubleshooting

PROBLEM	POSSIBLE CAUSE	SOLUTION
The light does not turn on at all.	1. The battery is discharged.	1. Charge the battery.
	2. The battery is bad.	2. Replace the battery.
	3. The LED fixture is bad.	3. Replace the LED fixture.
	4. The fuse is blown.	4. Replace the fuse.
	5. The controller is bad.	5. Check the controller.
The light turns on at dusk but does not turn on again at dawn (split run time).	1. The run time exceeds the maximum run time for your model and location.	1. Contact SOL for assistance.
	2. Low battery voltage caused by inclement weather.	2. Allow for two to three days of consecutive sunny weather to charge the battery pack.
	3. Low battery voltage caused by shading of the solar panel.	3. Clear tree branches and other obstructions from the vicinity of the solar panel.
	4. The batteries are bad.	4. Replace all three batteries
The red LED on the controller remains illuminated.	1. Low battery voltage caused by inclement weather.	1. Allow for two to three days of consecutive sunny weather to charge the battery pack.
The light does not operate every day.	1. Low battery voltage caused by shading of the solar panel.	1. Clear tree branches and other obstructions from the vicinity of the solar panel.
	2. The batteries are bad.	2. Replace all three batteries.
The fuse blows repeatedly.	1. There is a short circuit in the wiring.	1. Check all system wiring for a short circuit.

## 5.3 In-Warranty Service Instructions

A Returned Merchandise Authorization (RMA) number must be obtained from SOL Inc before equipment can be returned for repair or replacement under warranty.

To obtain an RMA, simply send an e-mail to [rma@solarlighting.com](mailto:rma@solarlighting.com). Be sure to include the information outlined below.

We require the following information before we can issue an RMA number:

- Model Number of the product being returned
- Serial Number of the product being returned
- A description of the problem
- The address to which the repaired or replaced product is to be shipped

Equipment being returned must be properly packaged to protect it from damage during shipment.

Shipping costs and insurance to SOL Inc are the responsibility of customer.

Upon verification of failure due to defects in materials or workmanship, we will either repair or replace the product at our discretion. The customer will be responsible for all shipping and handling charges for any equipment that is sent to SOL Inc in error (no definable problems).

## SOL FivePlus™ Warranty

SOL Inc. is an ISO 9001:2008 certified worldwide manufacturer that designs and manufactures its own products. Although the best scenario involves never having to actually use a company's warranty, we are proud to offer, what we believe is the BEST WARRANTY available in the industry, from a company that has been in business since 1990.

SOL warrants each new lighting system to be free from defects in materials and workmanship and to perform under normal use and service. SOL will, at its option, repair or replace any system or system component that is defective in materials or manufacture within a minimum of five (5) years after purchase. Additionally, specific items within SOL's system have extended warranty protection as defined below:

<u>Item</u>	<u>Period</u>
PV Module (mono/polycrystalline)	20 Years
Thin Film PV Module(s)	10 Years
Mounting Hardware	20 Years
LED Luminaire	5 Years
Fluorescent Ballast	2 Years
Wire Harnessing	10 Years
Charge controller & LED Driver	5 Years

Batteries provided by SOL have a limited warranty providing for battery replacement from the date of shipment, with the following pro-rated coverage:

- 0 to 2 years: 100% credit (user pays 0% of the replacement battery price)
- 2 to 3 years: 60% credit (user pays 40% of the replacement battery price)
- 3 to 4 years: 40% credit (user pays 60% of the replacement battery price)
- 4 to 5 years: 20% credit (user pays 80% of the replacement battery price)

SOL's liability on any claim for damages arising out of or in connection with the manufacture, sale, installation, delivery or use of the unit shall not exceed the purchase price of the system. The purchaser assumes and will hold harmless SOL in respect of all such loss.

For warranty information on SOL products please call +1 (772) 286-9461. Before returning any product or component to SOL, first obtain a Return Material Authorization (RMA) number and return requested items via prepaid shipping. Failure to do so may result in no issued credit, and SOL shall not be responsible for said items.

This warranty does not cover damage or malfunction, as determined by SOL's service technicians or engineers, due to abuse, misuse, incorrect installation or accident such as, but not limited to:

- Use of incorrect mounting hardware
- Failure to follow operating and installation instructions provided by SOL
- Failure to maintain & operate the equipment in accordance with all applicable safety standards and codes
- Failure to maintain & operate the system under SOL Inc specified operating conditions
- Vandalism, theft, fire, flood, "Acts of God", and other problems beyond the control of SOL
- Unauthorized or improper repairs or adjustments
- Labor costs to remove, service, troubleshoot and/or reinstall all or part of SOL systems, unless previously agreed to and authorized IN WRITING by SOL Inc. by either the Customer Service Manager, Quality Manager or CEO
- Equipment service, rental, and or tools required to remove, service, troubleshoot, and/or reinstall all or part of SOL systems, unless previously agreed to and authorized IN WRITING by SOL Inc by either the Customer Service, Manager, Quality Manager, or CEO
- Equipment not provided by SOL Inc. and components and equipment external to the SOL Inc. system
- The cost of repairing or replacing property other than the SOL Inc. system

The use of electrical components, hardware, fixtures or batteries not provided by SOL Inc. voids this warranty. This warranty is in lieu of all other express warranties and the implied warranty of merchantability and is limited to terms of this written warranty. This warranty grants you specific legal rights, and you may have other rights that vary from state to state.



Reliable. Renewable. Remarkable.

SOL Inc. | 3210 SW 42nd Avenue | Palm City, Florida 34990

[www.solarlighting.com](http://www.solarlighting.com)

E-mail support: [support@solarlighting.com](mailto:support@solarlighting.com)

Phone: +1.772.286.9461 | Toll: 800.959.1329 (USA & Canada)

Fax: +1.772.286.9616

Office Hours: Monday - Friday: 8:30am to 5:00pm (EST)

© 2010 SOL Inc. All rights reserved