

Oasys™ Shelter Lighting System

Integrated solar lighting system for all types of shelters

This inclusive system provides security lighting for kiosks, shelters and remote buildings.

FEATURES

- An all-inclusive security lighting system specifically engineered for rugged environments.
- Oasys™ unit holds white LED, batteries and intelligent controller. System also includes:
 - Solar pv collection panel.
 - Plug-and-play interconnects.
 - Mounting rack for solar pv panel.
- **Housing:** Marine grade aluminum housing with smooth powdercoat finish. Standard colors: white, black, bronze and green.
- **Security:** Front framed security with tamper resistant screws.
- **Weight:** 35 lbs.
- **System Voltage:** 12VDC
- **Panel Power:** 50, 80 and 125 Watts (depending on geographic location).
- **Battery:** NRGLife™ 12V sealed maintenance free GEL cell batteries rated at 12 Ah (housed within unit) with typical 5-night backup.
- **Reflector:** Prismatic optics utilizing Sol Max-Lite® Reflector.
- **Lens:** Polycarbonate flat clear lens.
- **LED Type:** High Flux Strip Type rated to 70,000 Hours (LM70).
- **LED Enclosure:** Water tight, sealed, dust and insect free.
- **Luminous Efficacy:** >85 lumens per Watt.



- **Color Temperature:** 5100K (bright white).
- **Operating Temperature (Amb.):** -40°F to 120°F.
- **Mounting:** LED fixture can be mounted separately from housing or integrated into front of housing unit.
- **Warranty:** 5 year limited system warranty and 20 year limited warranty on solar panels.

ADDITIONAL INFO

- Excellent color rendering optimizes human visual acuity and contrast, offering best in class night-time (scotopic) vision.
- “Instant-on” – no warm up or cold start issues.
- No risk of hazardous disposal; unlike CF, CCFL, LPS and HPS, which contain mercury.
- No energy costs and greenhouse gas emissions.

Sol® 
Reliable. Renewable. Remarkable.

Oasys™ Shelter Lighting System

Integrated solar lighting system for all types of shelters

SPECIFICATIONS

Oasys™ Models	Light Assembly Dimensions L x W x H (inches)	PV Panel Dimensions L x W x H (inches)	System Weight
OS-50	9.5 x 13 3/8 x 8 1/8	20.43 x 31.77 x 1.38	48 lbs
OS-80	9.5 x 13 3/8 x 8 1/8	47.28 x 21.14 x 1.81	57 lbs
OS-125	9.5 x 13 3/8 x 8 1/8	47 x 32 x 1.38	66 lbs

Solar panel specifications may vary by manufacturer.

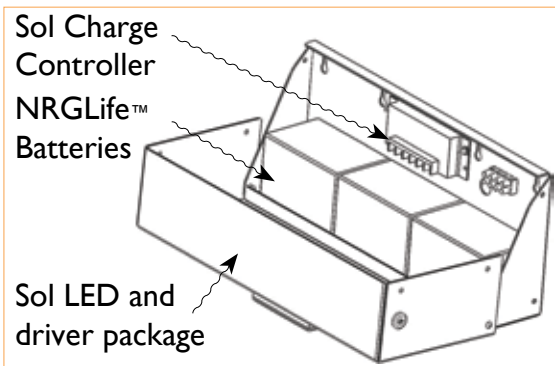

Self-contained low-profile shelter lighting package



Sol's Oasys™ shelter lighting - can be remotely mounted onto most shelter support systems



Optional thin film roof mounted solar panel

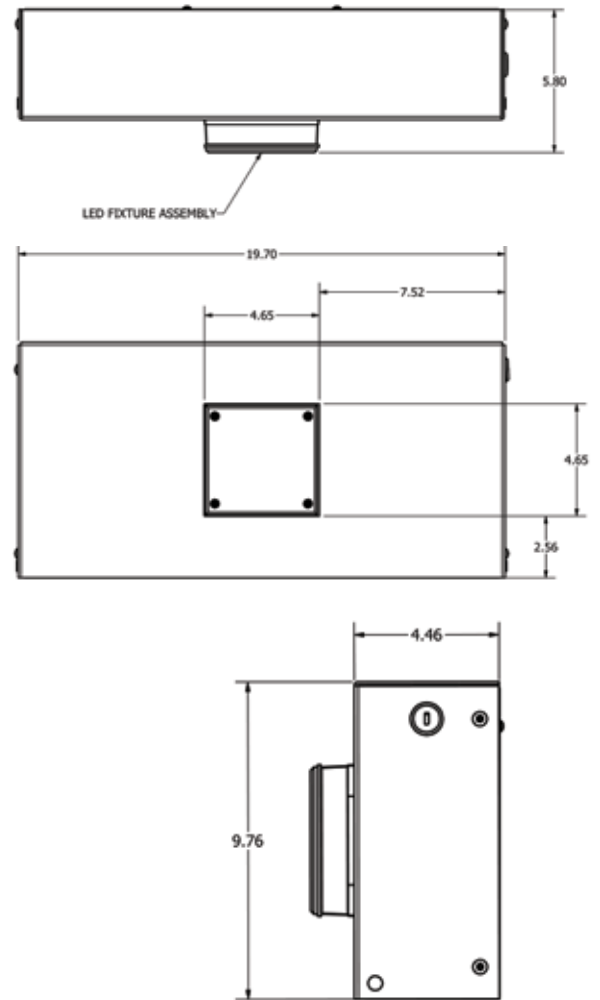

Sol® 
Reliable. Renewable. Remarkable.

Rev. 0909 MRKT-OASIS-001