

GreenWay™ Series Complete solar LED lighting solution system for safety and security

SOL provides trouble-free lighting wherever it's needed including pathways, walkways, hiking and biking trails, park and area security.



FEATURES

- Modular power unit and luminaire are separate allowing for solar array to face proper direction regardless of the orientation of the fixture.
- Solar array and battery box mounted at top of pole for vandal resistance.
- Vented aluminum battery box or optional pedestal battery base houses battery and controller.
- Maintenance free 100Ah (battery box) or 2-33Ah (pedestal base) rated gel cell battery(s) typically provides a minimum 5 night battery back-up in case of inclement weather.
- Sturdy corrosive resistant aluminum and stainless steel hardware throughout.
- Turn key system includes 20 foot direct burial pole.
- Luminaire recommended mounting height between 12 to 15 feet.
- Uniform light distribution – 12 foot mounting height typically provides 70 to 100 foot pole spacing.
- Installation in less than an hour with slipfit design.
- Marine (Sea-Side) Grade powder coated paint with 10 year warranty - available in bronze, gloss black, white or green. Other RAL colors available at an additional charge.
- Super efficient, bright, white light 5,100 K, state-of-the-art LED light source.
- The most efficient and aesthetically pleasing white light source in this wattage range.
- Excellent color rendering optimizes human visual acuity and contrast, offering best in class night-time vision.
- “Instant-on” – no warm up or cold start issues.
- Unlike conventional lights, no risk of hazardous disposal – CF, CCFL, LPS and HPS contain mercury.
- IDA Approved Dark Sky Friendly and IES full cut off certified fixtures available.
- System is  Certified.
- LEDs rated at 70,000 hours (L-70).
- Options: Pole Mounted or Remote Control Seasonal Switching is available to turn off fixture when evening illumination is not desired do to individual or seasonal event.
- FivePlus™ Warranty includes 10 years on electronics, wiring, fixtures and 20 years on mounting hardware and solar panels.

Sol® 
Reliable. Renewable. Remarkable.

GreenWay™ Series

Complete solar LED lighting solution system for safety and security

SPECIFICATIONS

Light Output

- Solid State LED
- LED pack produces regular light pattern
- Light color: 5100 K / CRI Index 80
- Lamp: 11.8 W, 12.9 W or 18.9 W
- LED Rating: 70,000 hours (L-70)
- Light Patterns: Type I (1) or Type V (5)
- IDA Dark Sky Certified Luminaires



Luminaire (standard)

- Polycarbonate Hemi Dome lens / "O" Ring Sealed
- IP 65 Rating
- Power-coated paint finish
- Dimensions: 5.25" x 9" x 11"
- Die cast corrosion resistant
- Condensation prevention
- Weight: 6 lbs.

Support Arm

- Length: 26.25 inches
- Grade "A" Corrosion Resistant Aluminum
- Weight: 12 lbs.

Battery Box

- Dimensions: 8.3" x 12.9" x 16"
- Grade "A" Corrosion Resistant Aluminum
- Weight: 9.5 lbs.

NRGLife™ Battery

- Gel Cell – No maintenance, 100 amp hour resistant
- Weight: 62 lbs.

Direct Burial Pole

- 4" I.D./4.5" O.D. Schedule 40 straight aluminum pole - standard up to 20 ft. for direct burial or threaded for pedestal base / Optional 24 ft. pole for longer burial depths in high wind applications
- Weight: max. 68 lbs.

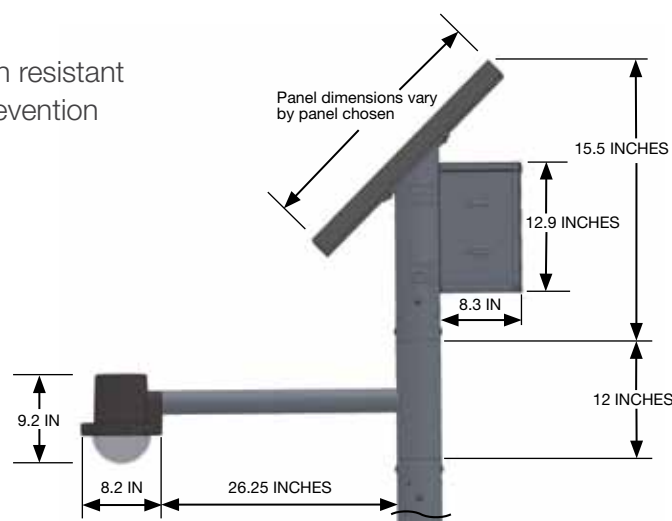

Model	Solar Power Array	SPA Dimensions (L x W x H inches)	Panel Power (output amps)	EPA (Effective Projective Area)	System Weight (with pole)
Greenway™ 50	50 Watts	27.05 x 20.06 x 1.81	2.37 amp @ 12V	5.60 sq. ft.	225 lb.
Greenway™ 80	80 Watts	39.48 x 26.06 x 1.81	4.55 amp @ 12V	7.18 sq. ft.	250 lb
Greenway™ 100	100 Watts	48.69 x 26.06 x 1.88	5.70 amp @ 12V	9.05 sq. ft.	295 lb
Greenway™ 125	125 Watts	58.58 x 26.06 x 1.88	7.14 amp @ 12V	10.05 sq. ft.	300 lb

Solar panel configurations may vary slightly by manufacturer



Reliable. Renewable. Remarkable.

rev. 0710 MRKT-GREEN-001